



**PARA LIGHT ELECTRONICS CO., LTD.**  
11F., No. 8, Jiankang Rd., Zhonghe Dist., New Taipei City 235, Taiwan,  
Tel: 886-2-2225-3733 Fax: 886-2-2225-4800  
E-mail: [para@para.com.tw](mailto:para@para.com.tw) <http://www.para.com.tw>

## DATA SHEET

PART NO. : LC151LYCT-XG-U1

REV : A / 0

CUSTOMER'S APPROVAL : \_\_\_\_\_ DCC : \_\_\_\_\_

DRAWING NO. : DS-51-24-025

DATE : 2024-03-23

Page : 1

FEATURES

- Dimension (L / W / H): 3.2 x 1.6 x 1.15 mm
- Color/ Dice Material: Yellow green light/ AlGaInp
- Colloid: Transparent concave colloid
- EIA standard packaging
- Environmental protection products meet ROHS requirements
- Suitable for automatic placement machine
- Suitable for infrared reflow soldering process

PACKAGE DIMENSIONS

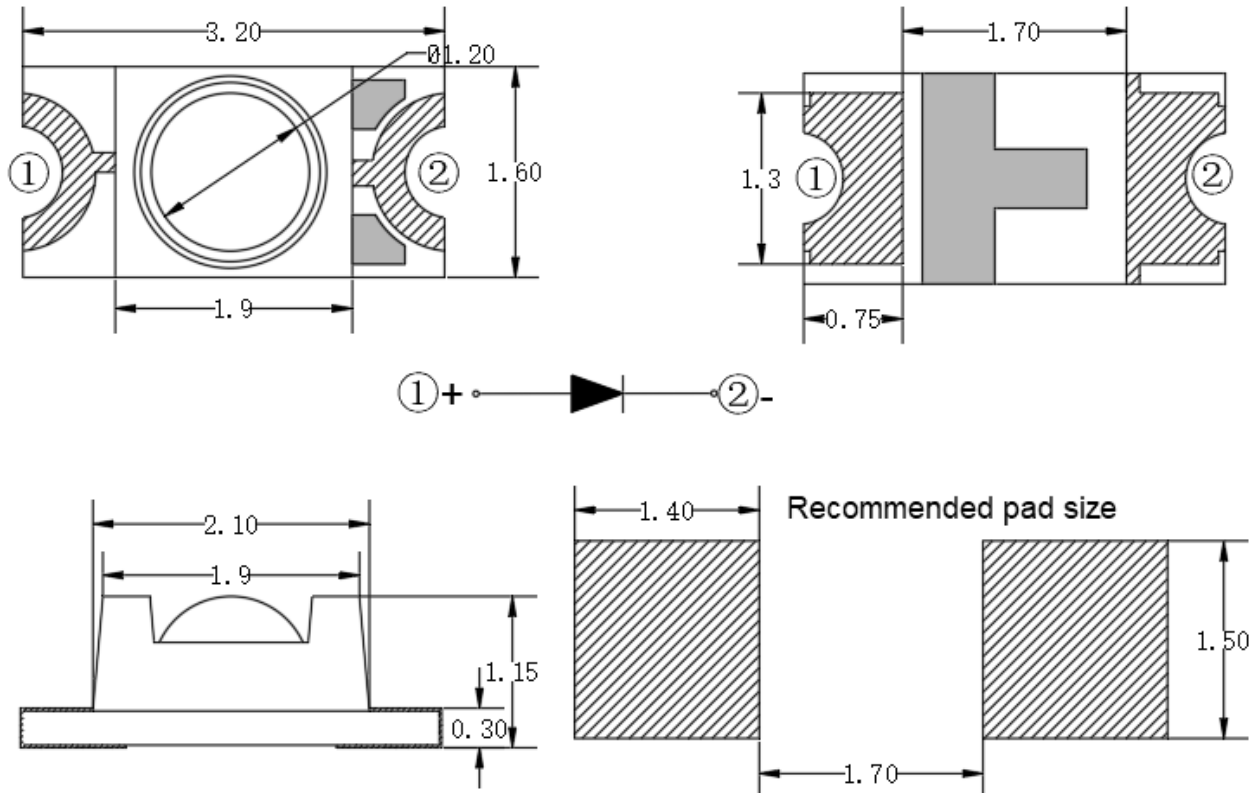

NOTES :

- 1.All dimensions are in millimeters
- 2.Tolerances are  $\pm 0.15$ mm unless otherwise noted
- 3.The Specifications in the datasheet are subject to change without notice.

**ABSOLUTE MAXIMUM RATING : ( Ta = 25°C )**

Symbol	Parameter	Rating	Unit
PD	Power consumption	65	mW
If	Forward Current	20	mA
Ifp	Maximum pulse current (1/10 duty cycle 0.1ms)	80	mA
VR	Reverse Voltage	5	V
ESD	Electrostatic discharge	1500	V
Topr	Operating Temperature Range	-40°C ~ + 85°C	°C
Tstg	Storage Temperature Range	-40°C ~ + 85°C	°C
Tsol	Reflow soldering : 255°C ,10s, Hand soldering : 300°C ,3s		

Note: Pulse width ≤0.1ms,Duty≤1/10

**ELECTRO-OPTICAL CHARACTERISTICS : ( Ta = 25°C )**

Parameter	Symbol	Min.	Typ.	Max.	Unit	Test Condition
Luminous Intensity	IV	170	-	350	mcd	IF=20mA
Dominant Wavelength	WD	586	---	595	nm	IF=20mA
Forward Voltage	VF	1.8	---	2.4	V	IF=20mA
Viewing Angle	2θ1/2	-	60	-	deg	IF=20mA
Reverse Current	IR	-	-	5	μA	VR=5V



# SURFACE MOUNT DEVICE LED

LC151LYCT-XG-U1

REV:A / 0

## Bin Code List

Parameter	Symbol	Bin Code	Min.	Max.	Unit	Test Condition
Luminous Intensity	IV	K	170	220	mcd	IF =20mA
		L	220	280		
		M	280	350		
Forward Voltage	VF	1E	1.8	2.0	V	IF =20mA
		2A	2.0	2.2		
		2B	2.2	2.4		
Dominant Wavelength	WD	Y3	586	589	nm	IF =20mA
		Y4	589	592		
		Y5	592	595		

### Note:

1. Tolerance of measurement of luminous intensity is  $\pm 20\%$ .
2. Tolerance of measurement of dominant wavelength is  $\pm 2\text{nm}$ .
3. Tolerance of measurement of forward Voltage is  $\pm 0.1\text{ V}$ .

Typical Electro-Optical Characteristics Curves ( @25°C)

Relative intensity VS wavelength

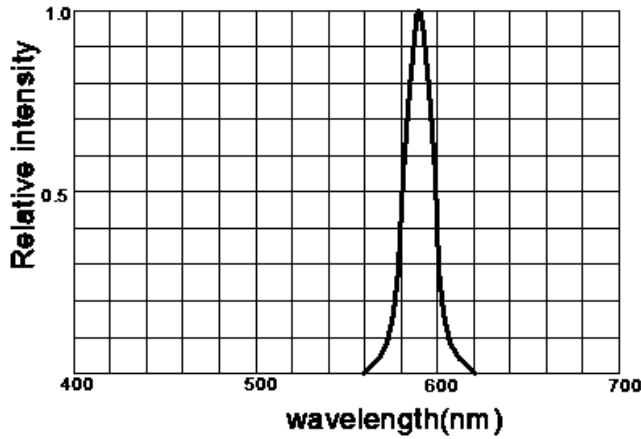

Voltage current relationship

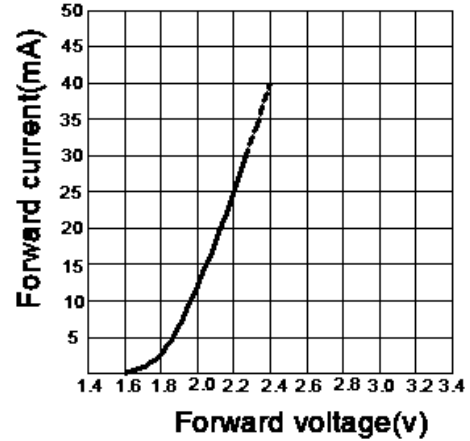

Current and ambient temperature

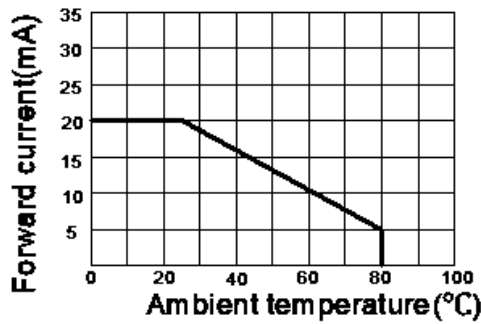

Relative light intensity vs current

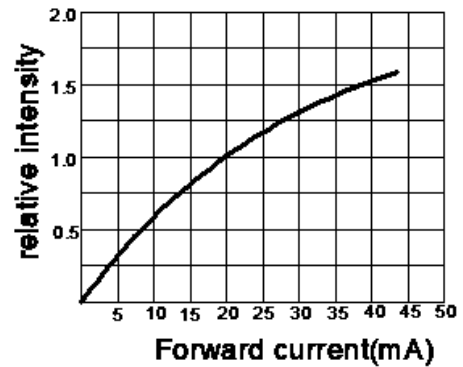

Relative light intensity vs ambient temperature

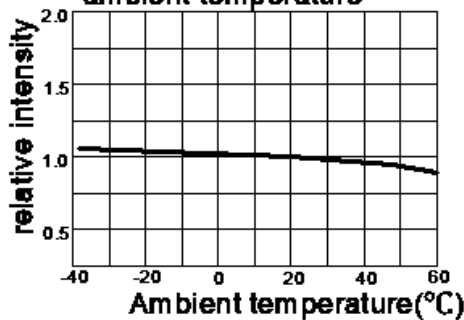

Radiation angle

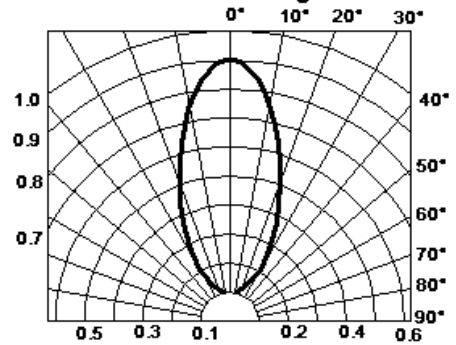

### Reel Dimensions

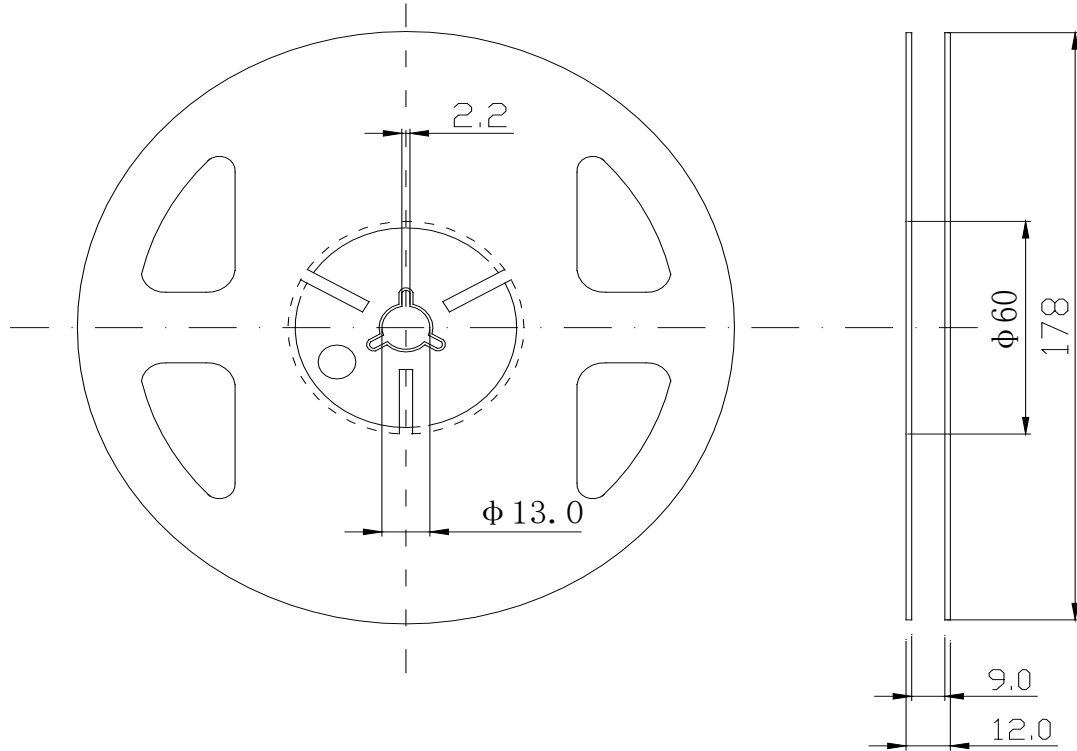

### Package Dimensions Of Tape And Reel

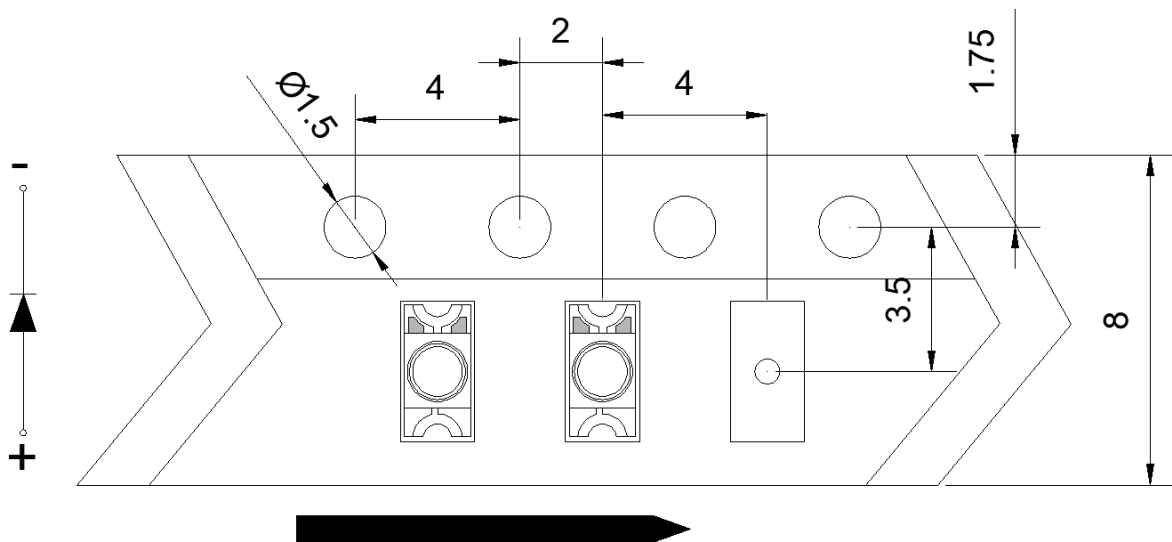

#### Notes:

1. Taping Quantity :3000pcs
2. The tolerances unless mentioned is  $\pm 0.15$ mm

Suggest Sn/Pb IR Reflow Soldering Profile Condition:

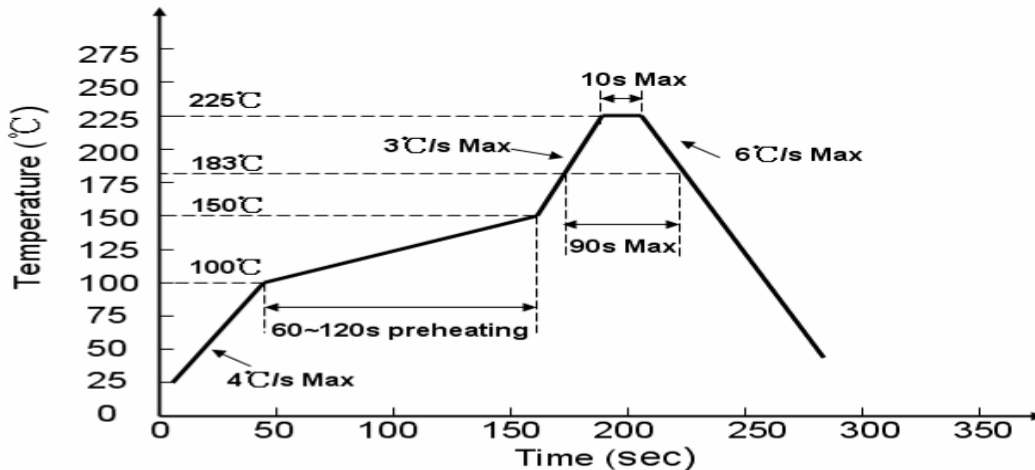

Suggest Pb-Free IR Reflow Soldering Profile Condition:

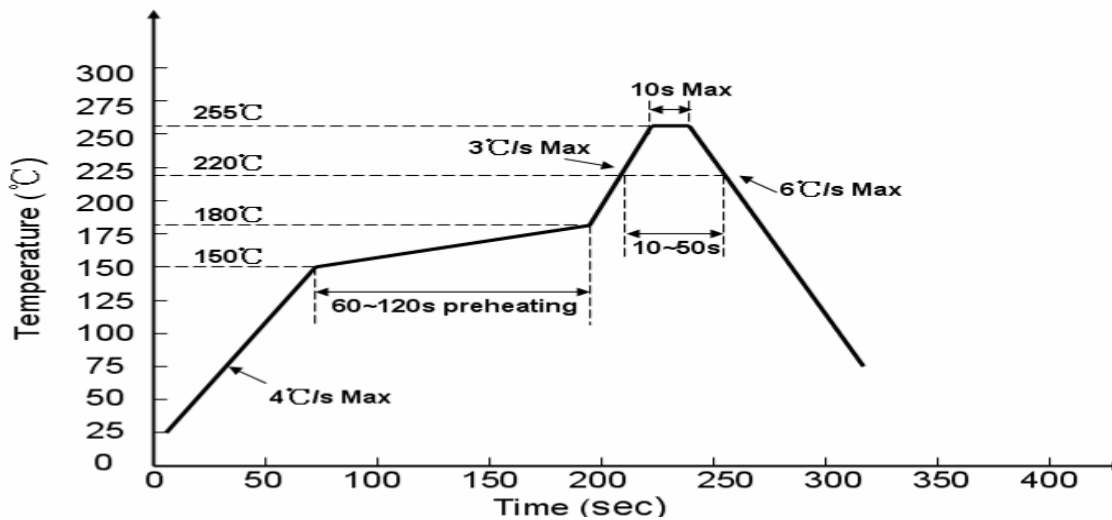

Failure

Criteria

Test Items	Symbol	Test condition	Failure Criteria
Forward Voltage	VF	IF=20mA	< (U.S.L*)x1.1
Reverse Current	IR	VR=5V	<10μA
Luminous Intensity	Iv	IF=20mA	> (L.S.L*)x0.7

Notes: 1.U.S.L means the upper limit of specified characteristics.

2.L.S.L means the Lower limit of specified characteristics



# SURFACE MOUNT DEVICE LED

LC151LYCT-XG-U1

REV:A / 0

## CAUTIONS

### use

1. Too high temperature will affect the brightness and other performance of LED, so in order to make the LED have better performance, we should keep the led away from heat source
2. Tolerance of photoelectric parameters:

Forward voltage	Brightness	Wavelength
(REF / VF): $\pm 0.1V$	(CAT / IV) : $\pm 15\%$	(HUE / XY): $\pm 2nm$

### Storage

1. The recommended storage environment is: temperature 5 ~ 30 ° C, humidity below 60%RH
2. LED is a humidity sensitive element. In order to avoid moisture absorption, it is recommended to store the LED in a sealed container with desiccant or in a nitrogen moisture-proof cabinet after opening the package
3. After unpacking, the components should be used within 168 hours (7 days); and the welding should be completed as soon as possible after placement
4. If the desiccant fails or the element is exposed to air for more than 168 hours (7 days), dehumidification should be performed, Baking conditions: 60 °C / 24 hours

### ESD (Electrostatic Discharge )-Protection

A LED (especially the blue, turquoise, purple, white and pink LEDs with InGaN structure chip) is an ESD sensitive component, and static electricity or power surge will damage the LED. ESD-damaged LEDs will exhibit abnormal characteristics such as high reverse leakage current, low forward voltage, or "no light-up" at low currents, etc.

Some advice as below should be noticed:

1. A conductive wrist strap or anti-electrostatic glove should be worn when handling these LEDs.
2. All devices, equipment, machinery, work tables and storage racks, etc. must be properly grounded(grounding impedance values within  $10\Omega$ ).
3. Use anti-static package or boxes to carry and storage LEDs. And ordinary plastic package or boxes is forbidden to use.
4. Use ionizer to neutralize the static charge during handling or operating.



**Cleaning**

Use alcohol-based cleaning solvents such as IPA (isopropyl alcohol) to clean LEDs if necessary.

**Welding**

1. Refer to the temperature curve on page 1 for reflow welding conditions;
2. The number of reflow soldering shall not exceed two times;
3. It is only recommended to use manual welding in the case of repair and heavy work. The maximum welding temperature should not exceed 300 °C and should be completed within 3 seconds.
4. The maximum power of soldering iron shall not exceed 30W;
5. During welding, it is forbidden to touch colloid at high temperature; after welding, it is forbidden to apply external force on colloid and bend PCB to avoid damage to components to hit.

**Other**

1. The definition of LED described in this specification shall be used in the scope of common electronic equipment (such as office equipment, communication equipment, etc.). If there is more severe Especially when the component failure or failure may directly endanger life and health (such as aerospace, transportation, transportation, medical treatment) Equipment, safety protection, etc.), please inform our business personnel in advance;
2. When high brightness LED products are on, it may cause damage to human eyes, so it is necessary to avoid looking directly at them from above;
3. For the purpose of continuous improvement, product appearance and parameter specifications may be changed without prior notice.

**Drive Method**

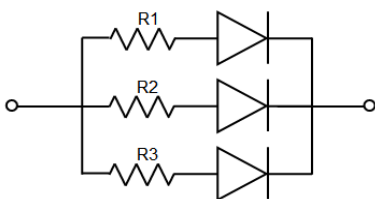

Circuit model A

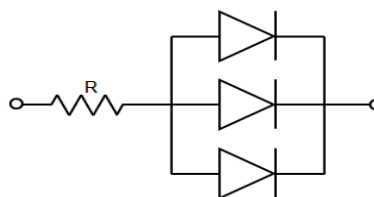

Circuit model B

(A) Recommended circuit.

(B) The difference of brightness between LED`s could be found due to the Vf-I<sub>f</sub> characteristics of LED.