



**PARA LIGHT ELECTRONICS CO., LTD.**  
11F, No.8, Jiankang Rd,Zhonghe Dist,New Taipei City 235, Taiwan  
Tel: 886-2-2225-3733 Fax: 886-2-2225-4800  
E-mail: [para@para.com.tw](mailto:para@para.com.tw) <http://www.para.com.tw>

## DATA SHEET

PART NO. : L-C153LBCT-HD-U1

REV : A / 1

CUSTOMER'S APPROVAL : \_\_\_\_\_ DCC : \_\_\_\_\_

DRAWING NO. : DS-51-16-024

DATE : 2021-11-20

Page : 1

PACKAGE DIMENSIONS

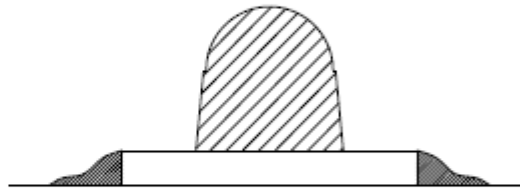
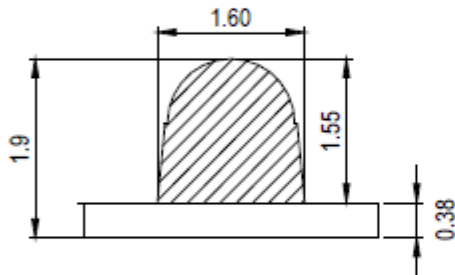
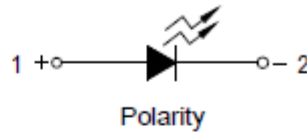
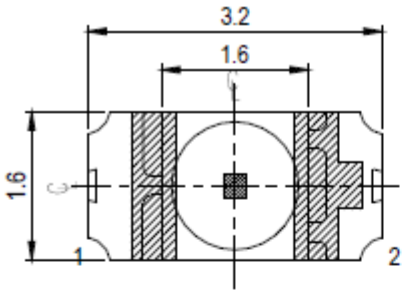

Recommended Solder Pad

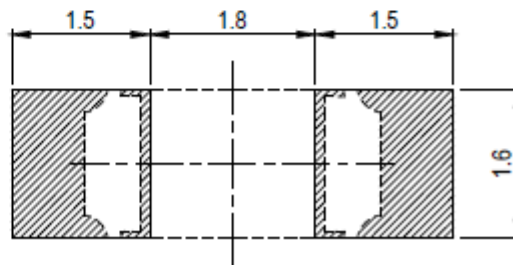
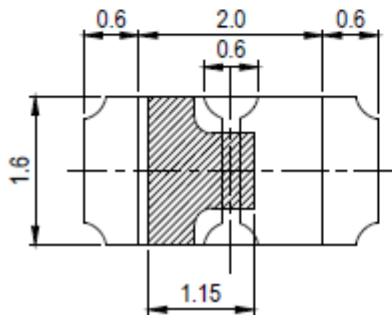

Note:

Tolerance unless mentioned is  $\pm 0.1$ mm, Unit = mm.



3.2\*1.6\*1.9 mm SMD LED

L-C153LBCT-HD-U1

REV:A / 1

### FEATURES

- \* 3.2\*1.6\*1.9 mm SMD LED
- \* LOW POWER CONSUMPTION
- \* Wide Viewing Angle
- \* LONGLIFE SOLID STATE RELIABILITY

### CHIP MATERIALS

- \* Dice Material : InGaN
- \* Light Color : Brilliant Blue
- \* Lens Color : WATER CLEAR

ABSOLUTE MAXIMUM RATING : ( Ta = 25°C )

SYMBOL	PARAMETER	Rating	UNIT
PD	Power Dissipation	95	mW
If	Forward Current	25	mA
Ifp	Peak Forward Current (1/10 duty cycle 0.1ms)	60	mA
Topr	Operating Temperature Range	-40 ~ + 85	°C
Tstg	Storage Temperature Range	-40 ~ + 100	°C
Tsol	Soldering Temperature	Reflow Soldering 260°C For 10 SEC Hand Soldering 350°C For 3 SEC	

ELECTRO-OPTICAL CHARACTERISTICS : ( Ta = 25°C )

Parameter	Symbol	Min.	Typ.	Max.	Unit	Test Condition
Luminous Intensity	Iv	1420	2850	3600	mcd	IF=20mA
Viewing Angle	2θ1/2	--	15	--	deg	IF=20mA
Dominant Wavelength	λD	460	470	475	nm	IF=20mA
Forward Voltage	VF	2.7	3.0	3.4	V	IF=20mA
Reverse Current	IR	--	--	10	μA	VR=5V

Typical Electro-Optical Characteristics Curves

25°C Ambient Temperature Unless Otherwise Noted

Fig.1-Forward Voltage Shift vs. Junction Temperature

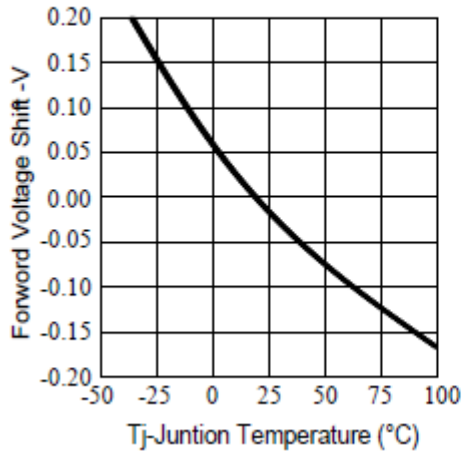

Fig.2-Relative Luminous Intensity vs. Forward Current

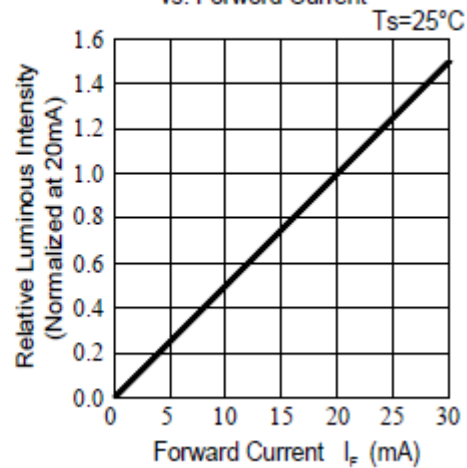

Fig.3-Relative Luminous Intensity vs. Junction Temperature

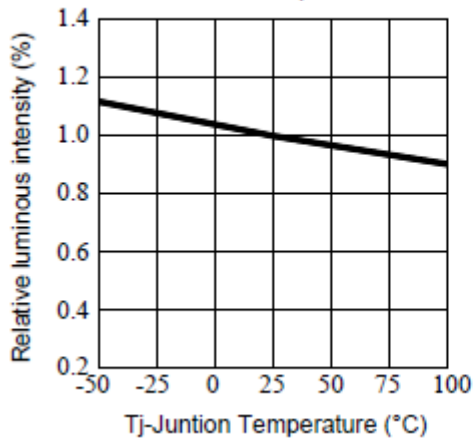

Fig.4-Forward Current vs. Forward Voltage

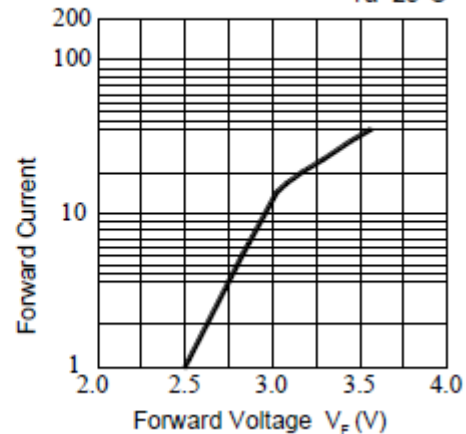

Fig.5-Max. Driving Forward Current vs. Soldering Temperature

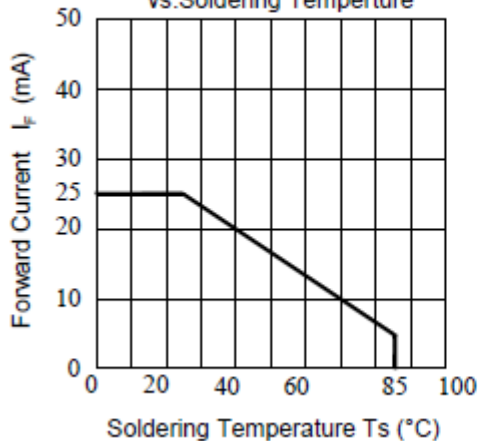
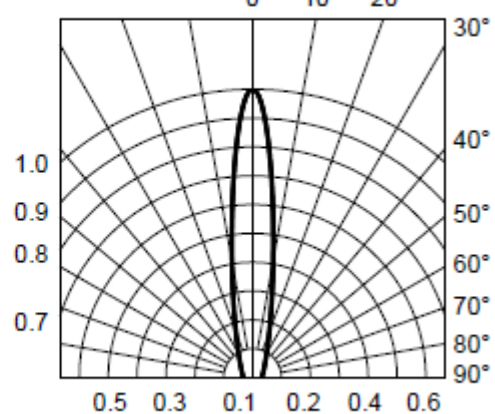

Fig.6-Radiation Diagram





3.2\*1.6\*1.9 mm SMD LED

L-C153LBCT-HD-U1

REV:A / 1

Bin Range of Luminous Intensity:

Bin Code	Min.	Max.	Unit	Condition
AW2	1420	1800	mcd	IF=20mA
AX1	1800	2250		
AX2	2250	2850		
AY1	2850	3600		

Note: Tolerance of Luminous Intensity:  $\pm 10\%$

Bin Range of Dominant Wavelength:

Bin Code	Min.	Max.	Unit	Condition
A5	460	465	nm	IF=20mA
A6	465	470		
A7	470	475		

Note: Tolerance of Dominant Wavelength:  $\pm 1\text{nm}$

Bin Range of Forward Voltage:

Bin Code	Min.	Max.	Unit	Condition
34	2.7	2.8	V	IF=20mA
35	2.8	2.9		
36	2.9	3.0		
37	3.0	3.1		
38	3.1	3.2		
39	3.2	3.3		
40	3.3	3.4		

Note: Tolerance of Forward Voltage:  $\pm 0.05\text{V}$

## Spectrum Distribution

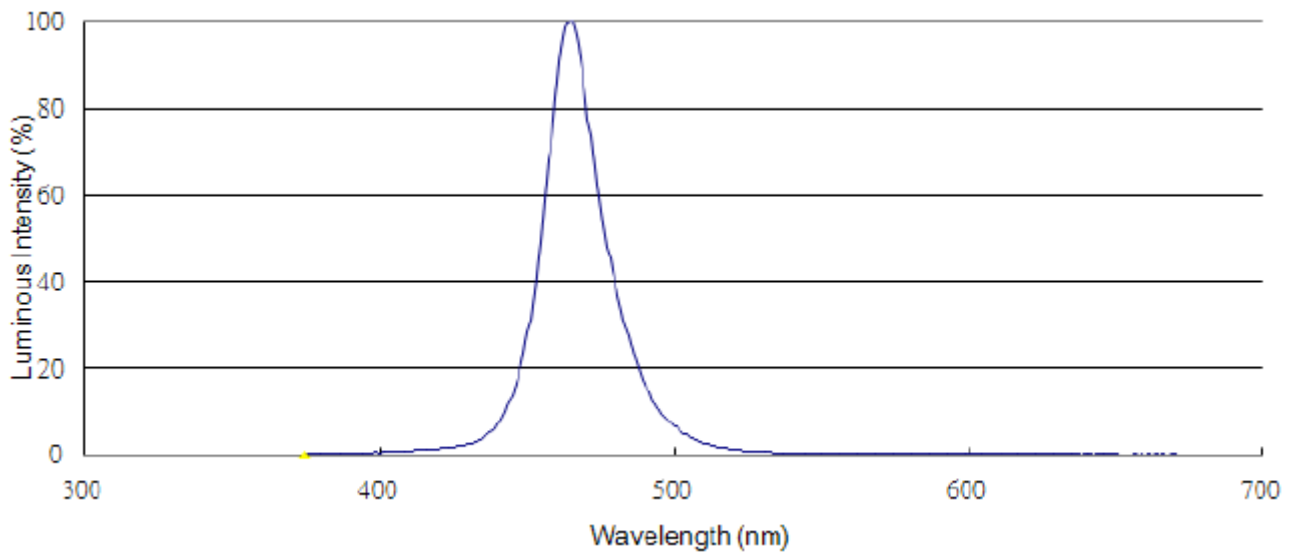

## Reel Dimensions

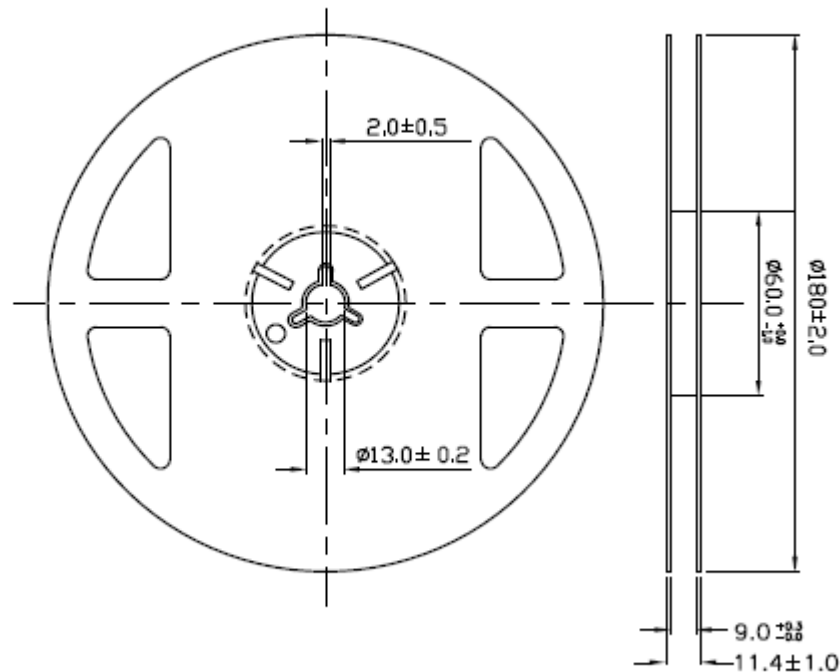

Note:  
Tolerances unless mentioned  $\pm 0.1$  mm, Unit = mm.

Carrier Tape Dimensions: Loaded Quantity 2000 pcs Per Reel

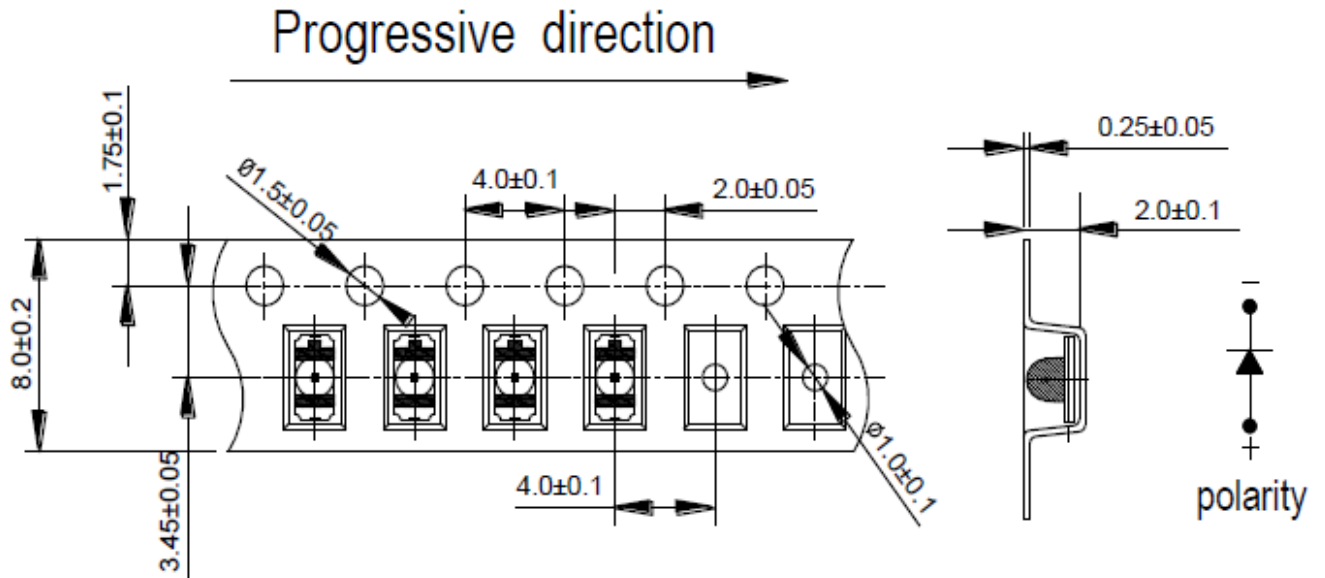

Note:

1. Tolerance unless mentioned is  $\pm 0.1$  mm, Unit = mm.
2. Minimum packing amount is 1000 pcs per reel.

**Moisture Resistant Packing Process**

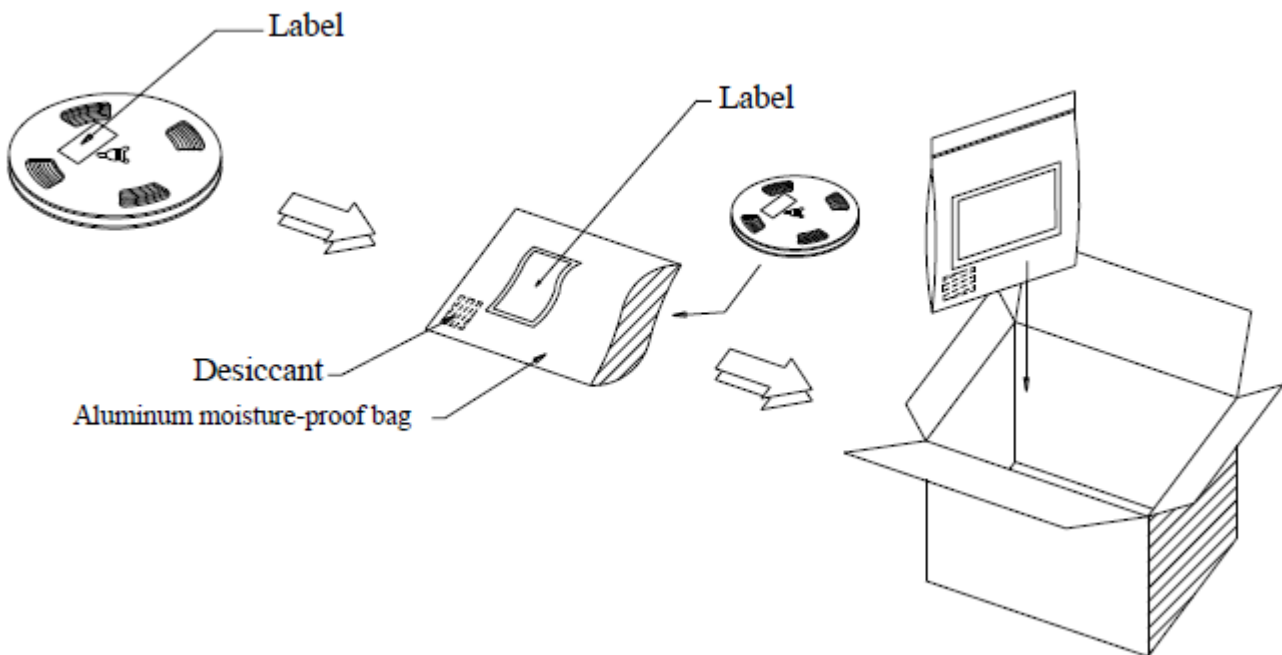



3.2\*1.6\*1.9 mm SMD LED

L-C153LBCT-HD-U1

REV:A / 1

### Reliability Test Items and Conditions

The reliability of products shall be satisfied with items listed below.

Confidence level : 90%

LTPD : 10%

No.	Items	Test Condition	Test Hours/Cycles	Sample Size	Ac/Re
1	Reflow Soldering	Temp. : 260°C/10sec.	6 Min.	22 PCS.	0/1
2	Thermal Shock	H : +100°C 5min ∩ 10 sec L : -10°C 5min	300 Cycles	22 PCS.	0/1
3	Temperature Cycle	H : +100°C 15min ∩ 5 min L : -40°C 15min	300 Cycles	22 PCS.	0/1
4	High Temperature/Humidity Reverse Bias	Ta=85°C,85%RH	1000 Hrs.	22 PCS.	0/1
5	Low Temperature Storage	Ta=-40°C	1000 Hrs.	22 PCS.	0/1
6	High Temperature Storage	Ta=100°C	1000 Hrs.	22 PCS.	0/1
7	DC Operation Life	Ta=25°C, I <sub>F</sub> = 20 mA	1000 Hrs.	22 PCS.	0/1



### Precautions for Use

#### 1. Over-current-proof

Customer must apply resistors for protection; otherwise slight voltage shift will cause big current change (Burn out will happen).

#### 2. Storage

2.1 Do not open moisture proof bag before the products are ready to use.

2.2 Before opening the package: The LEDs should be kept at 30°C or less and 90%RH or less.

2.3 After opening the package: The LED's floor life is 1 year under 30°C or less and 60% RH or less. If unused LEDs remain, it should be stored in moisture proof packages.

2.4 If the moisture absorbent material (silica gel) has faded away or the LEDs have exceeded the storage time, baking treatment should be performed using the following conditions.

Baking treatment: 60±5°C for 24 hours.

#### 3. Soldering Condition

##### 3.1 Pb-free solder temperature profile

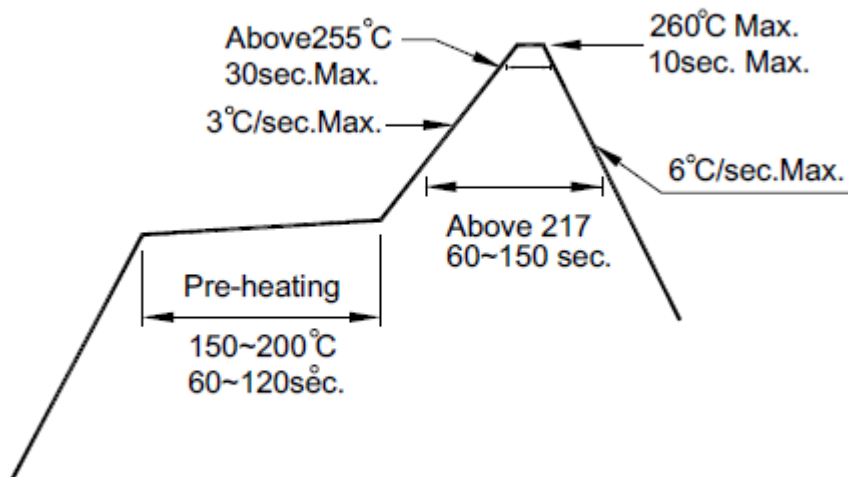

3.2 Reflow soldering should not be done more than two times.

3.3 When soldering, do not put stress on the LEDs during heating.

3.4 After soldering, do not warp the circuit board.

#### 4. Soldering Iron

Each terminal is to go to the tip of soldering iron temperature less than 350°C for 3 seconds within once in less than the soldering iron capacity 25W. Leave two seconds and more intervals, and do soldering of each terminal. Be careful because the damage of the product is often started at the time of the hand solder.

#### 5. Repairing

Repair should not be done after the LEDs have been soldered. When repairing is unavoidable, a double-head soldering iron should be used (as below figure). It should be confirmed beforehand whether the characteristics of the LEDs will or will not be damaged by repairing.