



PARA LIGHT ELECTRONICS CO., LTD.

11F., No. 8, Jiankang Rd., Zhonghe Dist., New Taipei City 235, Taiwan,
Tel: 886-2-2225-3733 Fax: 886-2-2225-4800
E-mail: para@para.com.tw www.paralighttaiwan.com

DATA SHEET

PART NO.: LS2812HECT-U1

REV: A / 0

CUSTOMER'S APPROVAL : _____

DCC : _____

DRAWING NO. : DS-31P-18-0171

DATE : 2018-08-22 PAGE

1 of 11

Features

Package (L/W/H) : 2.8x0.8x1.2 mm
Ultra Bright Standard Red
Water Clear Flat Mold
EIA STD Package
Meet ROHS, Green Product
Compatible With SMT Automatic Equipment
Compatible With Infrared Reflow Solder Process

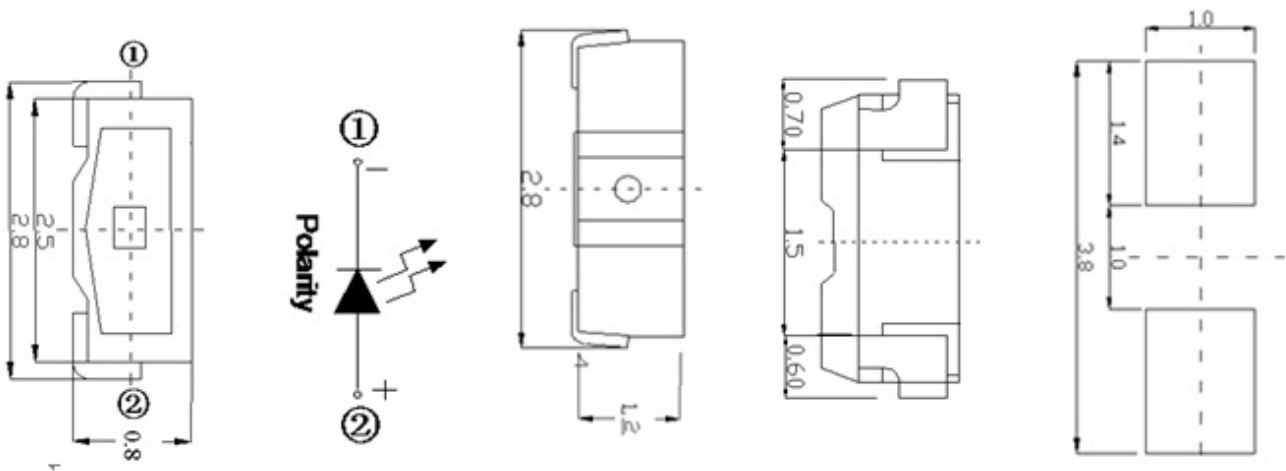
Package Profile & Soldering PAD Suggested

- Notes: 1. All dimensions are in millimeters
2. Tolerance is ± 0.10 mm unless otherwise noted



SURFACE MOUNT DEVICE LED

Part No. : LS2812HECT-U1

REV: A / 0

Absolute Maximum Ratings $T_a=25^{\circ}\text{C}$

Parameter	Symbol	Rating	Unit
Power Dissipation	Pd	60	mW
Peak Forward Current	IFP	100	mA
DC Forward Current	IF	25	mA
Reverse Voltage	VR	5	V
Operating Temperature Range	Topr	$-30^{\circ}\text{C} \sim +85^{\circ}\text{C}$	
Storage Temperature Range	Tstg	$-40^{\circ}\text{C} \sim +90^{\circ}\text{C}$	
Soldering Condition	Tsol	Reflow soldering : 260°C 10s	
		Hand soldering : 300°C 3s	

Electrical Optical Characteristics $T_a=25^{\circ}\text{C}$

Parameter	Symbol	Min.	Typ.	Max.	Unit	Test Condition
Luminous Intensity	IV	--	140	--	mcd	IF = 20mA
Viewing Angle	2 θ 1/2	---	120	---	deg	IF = 20mA
Dominant Wavelength	λ_d	615		630	nm	IF = 20mA
Peak Wavelength	λ_p		630		nm	IF = 20mA
Color Temperature	VF	1.8		2.4	V	IF = 20mA
Forward Voltage	IR	---	---	5	μA	VR = 5V
Spectral Line Half-Width	$\Delta\lambda$		15		nm	IF = 20mA

Typical Electrical-Optical Characteristics Curves

Forward Current VS. Forward Voltag (Ta=25°C)

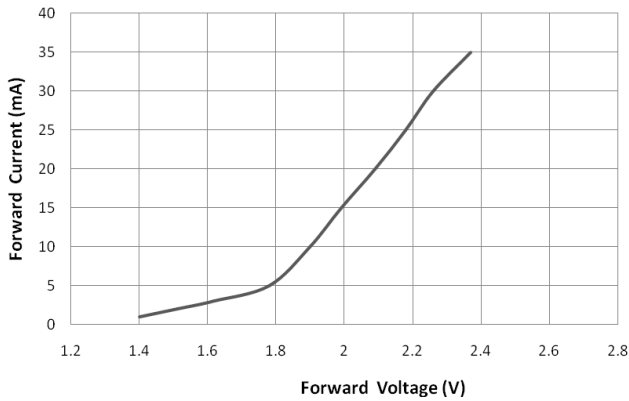

Spectrum Distribution (Ta=25°C)

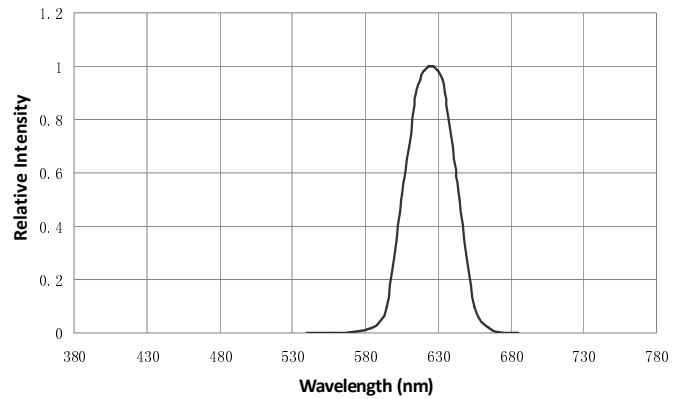

Relative Intensity VS. Ambient Temperature (Ta=25°C)

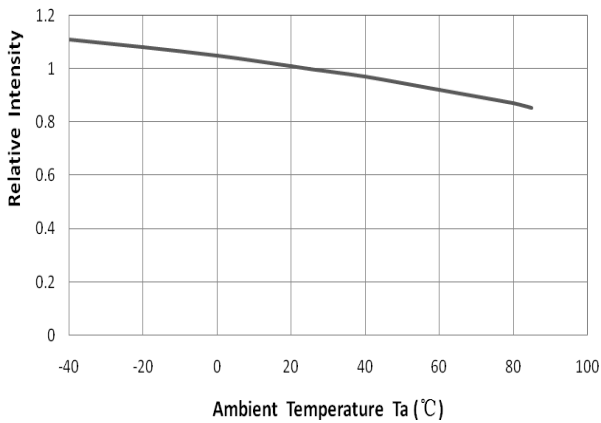

Relative Intensity VS. Forward Current (Ta=25°C)

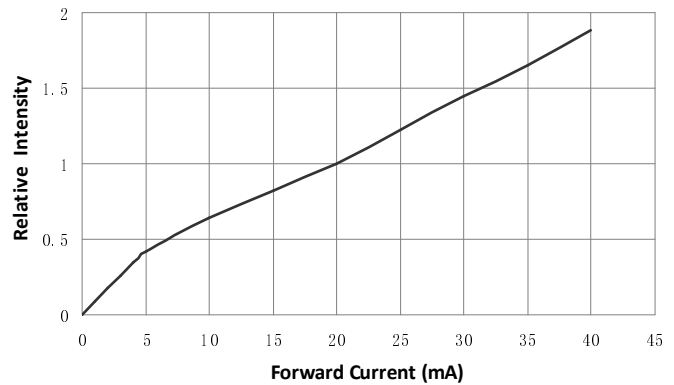

Maximum Forward Current VS. Ambient temperature

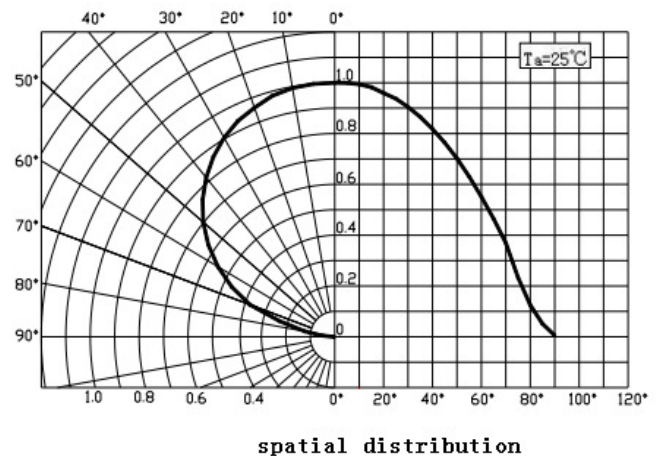
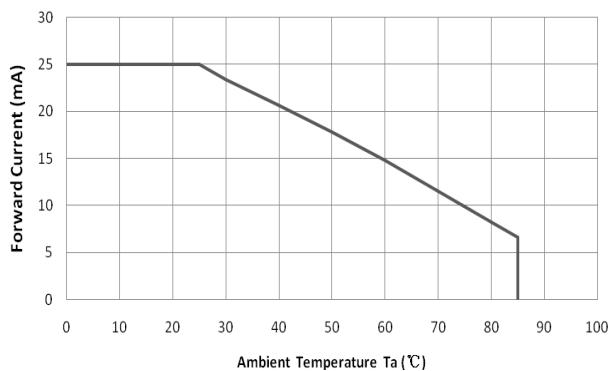



SURFACE MOUNT DEVICE LED

Part No. : LS2812HECT-U1

REV: A / 0

Bin Range of Luminous Intensity

Bin	Min	Max	Unit	Condition
L1	115	140	MCD	IF = 20mA
L2	140	180		
M1	180	230		
M2	230	285		

Notes: Tolerance of Luminous Intensity: $\pm 11\%$

Bin Range of Forward Voltage

Bin	Min	Max	Unit	Condition
1	1.8	2.0	V	IF = 20mA
2	2.0	2.2		
3	2.2	2.4		

Notes: Tolerance of Forward Voltage: $\pm 0.02V$

Bin Range of Wavelength

Bin	Min	Max	Unit	Condition
A	615	620	nm	IF = 20mA
B	620	625		
C	625	630		

Notes: Tolerance of Wavelength: $\pm 1nm$



Reel And Tape Dimensions

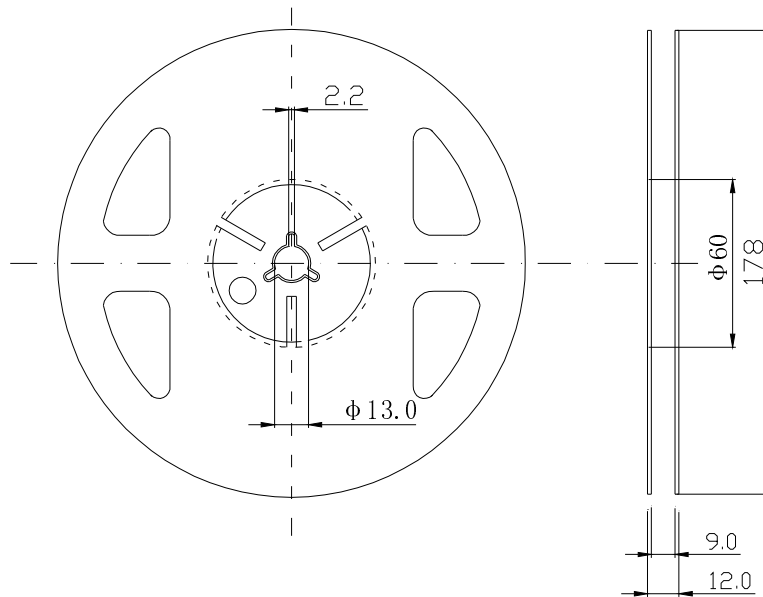
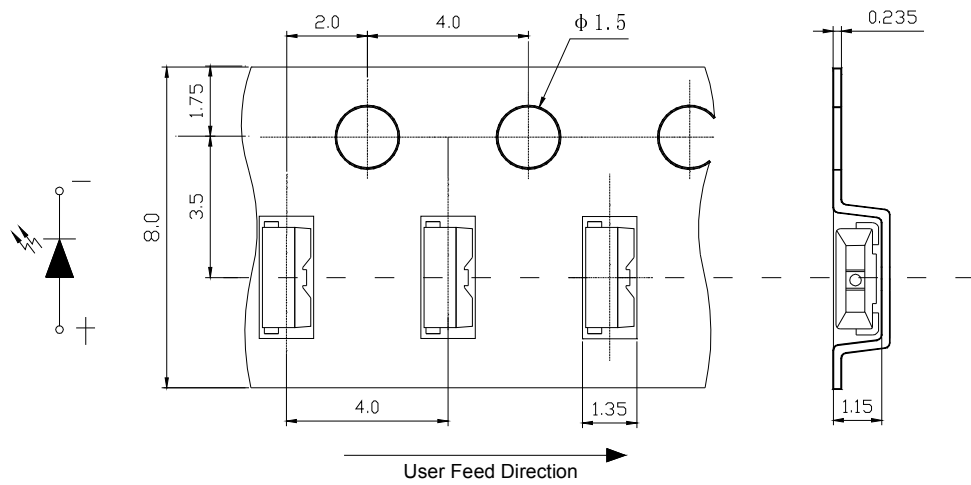

- Notes: 1. All dimensions are in millimeters
 2. Tolerance is ± 0.1 mm unless otherwise noted

Tape Leader & Trailer Dimensions And Reel

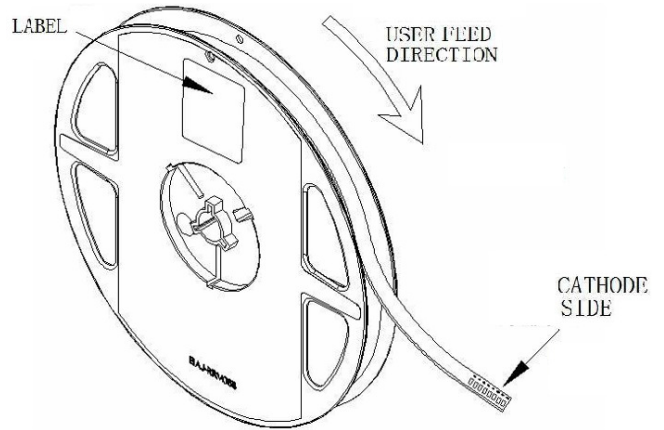
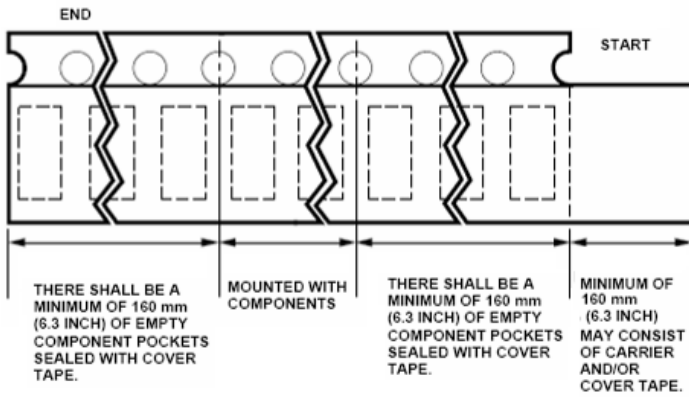

Label Explanation

	光鼎电子有限公司
CUS. PART NO. :	
CUSTOMER:	
PART NO: XXXXXXXXXXXX	IV:
	VF:
LOT NO: XXXXXXXX	WD:
	QC:
Qty: XXXXPCS	
Date: XXXXXXXX	ROHS

Soldering Profile Suggested For Lead Free Solder

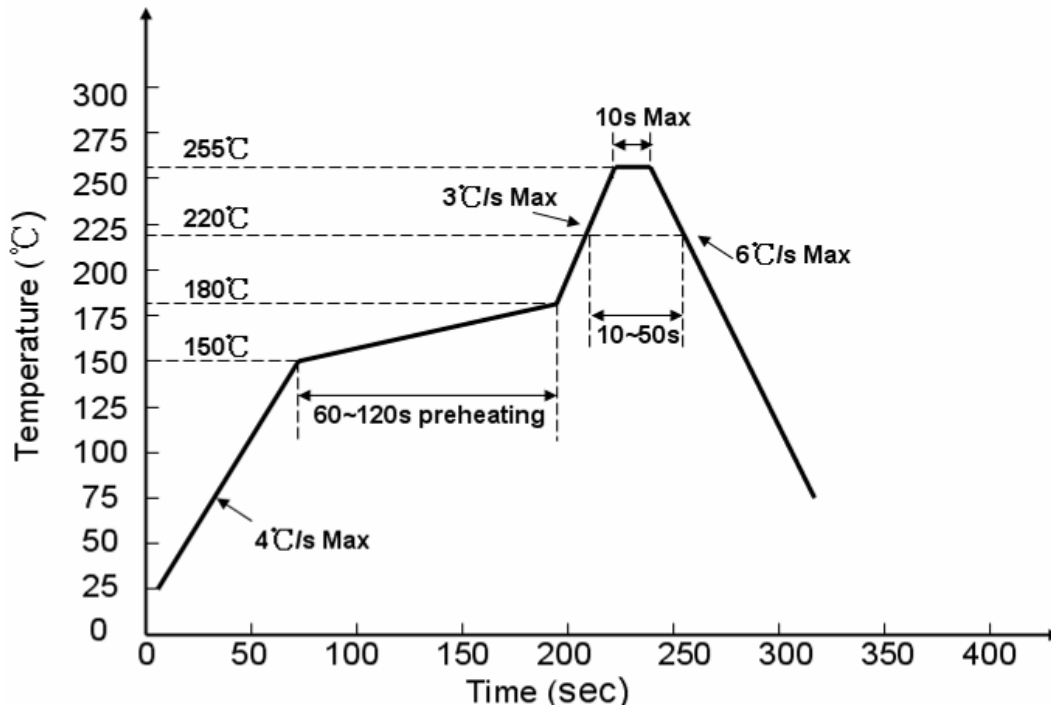

Reliability Test

Classification	Test Item	Test Condition	Reference Standard	Reference Standard
Endurance Test	Operation Life	25mA test Ta= Under Room Temperature As Per Data Sheet Maximum Rating	1000 HRS -24 HRS +72 HRS	MIL-STD-750D:1026 MIL-STD-883D:1005 JIS C 7021:B-1
	High Temperature, High Humidity Storage	IR-Reflow In-Board, 2 Times Ta= 85±5°C, RH= 85%	1000 HRS + 2 HRS	JESD22-A101
	High Temperature Storage	Ta= 105±5°C	1000 HRS -24HRS +72 HRS 1000 HRS -24HRS +72 HRS	MIL-STD-883D:1008 JIS C 7021:B-10 JIS C 7021:B-12
	Low Temperature Storage	Ta= -40±5°C	1000 HRS -24 HRS +72 HRS	MIL-STD-750D:1026 MIL-STD-883D:1005 JIS C 7021:B-1

Environmental testing	Temperature Cycling	100°C ~ 25°C ~ -40°C ~ 25°C 30mins 5mins 30mins 5mins	100 Cycles	MIL-STD-202F: 107D MIL-STD-750D: 1051
	Thermal Shock	IR-Reflow In-Board, 2 Times 100 ± 5°C ~ -40°C ± 5°C 10mins 10mins	100 Cycles	MIL-STD-202F: 107D MIL-STD-750D:
	Reflow Pb Free Process	Peak temperature range 260°C 10s max		MIL-STD-750D: 2031.2 J-STD-020C

Criteria For Judging Damage

Test items	Symbol	Test Condition	Criteria For Judgement	
			Min	Max
Forward Voltage	VF	IF=20mA		U. S. L) x1. 1
Reverse Current	IR	VR=5V		U. S. L) x2. 0
Luminous Flux	med	IF=20mA	L. S. L) x0. 7	

U.S.L: Upper standard level

L.S.L: Lower standard level

Cautions

Application

1. A LED is a current-operated device. The slight shift of voltage will cause big change of current, which will damage LEDs. Customer should use resistors in series for the Over-Current-Proof
2. In order to ensure intensity uniformity on multiple LEDs connected in parallel in an application, it is recommended to use individual resistor separately, as shown in Circuit A below. The brightness of each LED shown in Circuit B might appear difference due to the differences in the I-V characteristics of those LEDs.

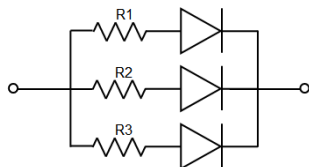

Circuit model A

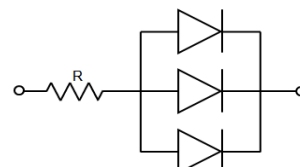

Circuit model B

3. High temperature may reduce LEDs' intensity and other performances, so keeping it away from heat source to get good performance is necessary.

4. Rank Tolerance

REF / VF $\pm 0.02V$

CAT / IV $\pm 10\%$

X / Y ± 0.005

Storage

1. Before opening original package, it is recommended to store them in the following environment:

Temperature: 5°C~30°C, Humidity: 85%RH max. When the inventory over 3 months, Should be done before treatment using dehumidification, Temperature: 60°C/8 hours.

2. After opening original package, the storage ambient for the LEDs should be in 5~30°C temperature and 60% or less relative humidity

3. In order to avoid moisture absorption, it is recommended that the LEDs that out of the original package should be stored in a sealed container with appropriate desiccant, or in desiccators with nitrogen ambient.

4. The LEDs should be used within 168hrs (7days) after opening the package. Once been mounted, soldering should be quick.

5. If the moisture absorbent material (silica gel) has faded away or the LEDs stored out of original package for more than 168hrs (7 days), baking treatment should be performed using the conditions: 60°C at least 24 hours.

ESD (Electrostatic Discharge)-Protection

A LED (especially the Blue White and Green product) is an ESD sensitive component, and static electricity or power surge will damage the LED. ESD-damaged LEDs will exhibit abnormal characteristics such as high reverse leakage current, low forward voltage, or "no light-up" at low currents, etc. Some advice as below should be noticed:

1. A conductive wrist strap or anti-electrostatic glove should be worn when handling these LEDs
2. All devices, equipment, machinery, work tables and storage racks, etc. must be properly grounded
Grounding impedance value within 10Ω
3. Use anti-static package or boxes to carry and storage LEDs. And ordinary plastic package or boxes is forbidden to use.
4. Use ionizer to neutralize the static charge during handling or operating.
5. All surfaces and objects within 1 ft close to LEDs measure less than 100V.

Cleaning

Use alcohol-based cleaning solvents such as IPA (isopropyl alcohol) to clean LEDs if necessary

Soldering

1. Soldering condition refer to the draft "Soldering Profile Suggested" on page 2.
2. Reflow soldering should not be done more than 2 times.
3. Manual soldering is only suggested on repair and rework. The maximum soldering temperature should not exceed 300°C within 3 sec. And the maximum capacity of soldering iron is 30W in power.
4. During the soldering process, do not touch the lens at high temperature.
5. After soldering, any mechanical force on the lens or any excessive vibration shall not be accepted to apply, also the circuit board shall not be bent as well.

Others

1. The LEDs described here are intended to be used for ordinary electronic equipment (such as office equipment, communication equipment and household applications). Consult Harvatek's Sales in advance for the applications in which exceptional reliability is required, particularly when the failure or malfunction of the LEDs may directly jeopardize life or health. (such as in aviation, transportation, traffic control equipment, medical and life support systems and safety devices).
2. The light output from the high luminous intensity LEDs may cause injury to human eyes when viewed directly.
3. The appearance and specifications of the product may be modified for improvement without prior notice.