



PARA LIGHT ELECTRONICS CO., LTD.

11F., No. 8, Jiankang Rd., Zhonghe Dist., New Taipei City 235, Taiwan,
Tel: 886-2-2225-3733 Fax: 886-2-2225-4800
E-mail: para@para.com.tw www.paralighttaiwan.com

DATA SHEET

PART NO.: L-T670WDT-CW-U1

REV: A / 0

CUSTOMER'S APPROVAL : _____ DCC : _____

DRAWING NO. :DS-31P-18-0170 DATE : 2018-08-22 PAGE 1 of 10



SURFACE MOUNT DEVICE LED

PartNo. : L-T670WDT-CW-U1

REV: A / 0

◆FeatureS

TOP LED Type

Size (mm) :3.5*2.8*1.9 Emitting Color: White

Wide view angle at 120° SMT package

Suitable for all SMT assembly and soldering method

Pb-free Reflow soldering application RoHS Compliant

◆Applications:

Light Strips Indicators Illuminations Mobile Phones

LCD Backlight Interior automotive

Decorative lighting

◆Emitter

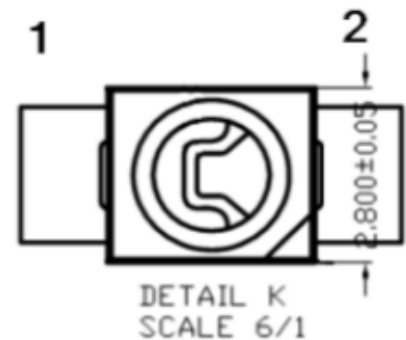
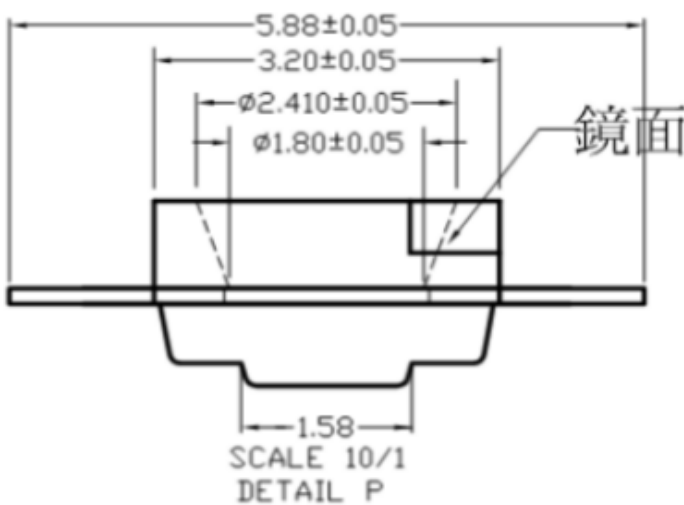

Note:

- Super High brightness of surface mount LED
- Sorting for I_v and $V_f@20mA$ of if
- Compatible to IR reflow soldering.
- The tolerances unless mentioned is $\pm 0.2mm$, Unit = mm



SURFACE MOUNT DEVICE LED

Part No. : L-T670WDT-CW-U1

REV: A / 0

Absolute Maximum Rating

Item	Symbol	Absolute Maximum Rating	Unit
Forward Current	IF	20	mA
Peak Forward Current	IFP	50	mA
Reverse Voltage	VR	5	V
Electrostatic discharge	ESD	2000	V
Operating Temperature	TOPR	-35~+85	°C
Storage Temperature	TSTG	-40~+90	°C
Soldering Temperature	TSOL	Reflow Soldering: 220°C for 5 sec Hand Soldering: 260°C for 3 sec	

Electro-Optical Characteristics (Ta=25°C)

Item	Symbol	Condition	Min	Typ	Max	Unit
Forward Voltage	VF	IF=20mA	2.8	3.0	3.2	V
Reverse Current	IR	VR=5V			5	uA
Viewing Angle	2θ 1/2	IF=20mA			120	deg
Light intensity	IV	IF=20mA	2000	2500	3000	mcd
Luminous Flux	Φ	IF=20mA	6	7	8	lm
Color temperature	CT	IF=20mA		9000		K
Color-rendering index	Ra	IF=20mA		72		

Notes:

1. Work absolute ratings Ta=25°C
2. Tolerance of measurement of forward voltage±0.1V



SURFACE MOUNT DEVICE LED

Part No. : L-T670WDT-CW-U1

REV: A / 0

Chromaticity Coordinates of Bin Code

Bin Code	CIE_x	CIE_y	Bin Code	CIE_x	CIE_y
A1	0.2534	0.2388	A4	0.2865	0.3053
	0.2644	0.261		0.2975	0.3275
	0.2711	0.2564		0.3038	0.3218
	0.2602	0.2346		0.2929	0.3
A2	0.2644	0.261			
	0.2755	0.2832			
	0.282	0.2782			
	0.2711	0.2564			
A3	0.2755	0.2832			
	0.2865	0.3053			
	0.2929	0.3			
	0.282	0.2782			

Taping Specifications

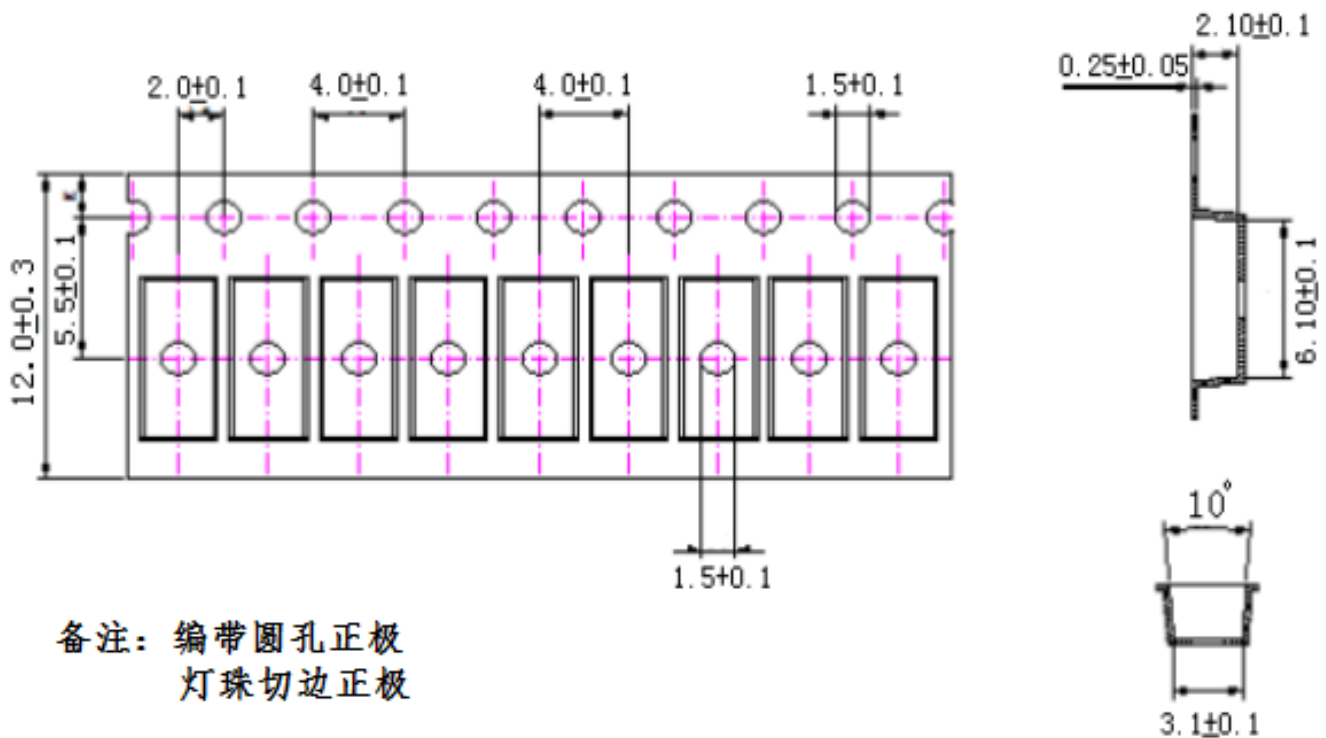



SURFACE MOUNT DEVICE LED

Part No. : L-T670WDT-CW-U1

REV: A / 0

Label Explanation

光鼎电子有限公司

CUS. PART NO. :

CUSTOMER:

PART NO: XXXXXXXXXXXX IV:

 VF:

LOT NO: XXXXXXXX CIE:

 QC:

Qty: XXXXPCS

Date: XXXXXXXX ROHS

Soldering Profile Suggested

1、For Lead Solder

2、For Lead Free Solder

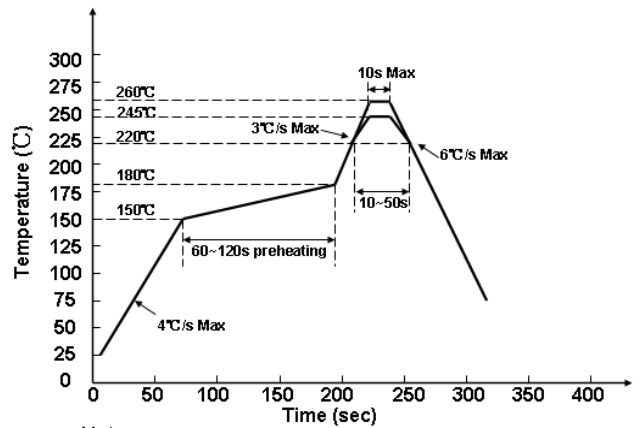
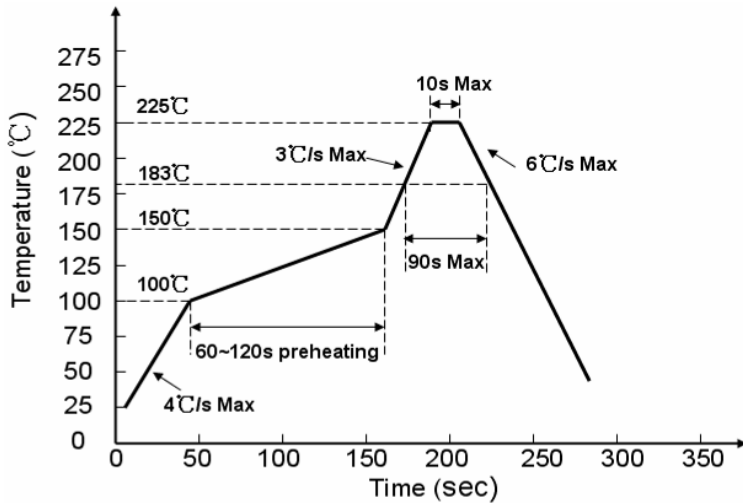

Notes:
We recommend the soldering temperature $245 \pm 5^\circ\text{C}$;
The maximum temperature should be limited to 260°C .



SURFACE MOUNT DEVICE LED

Part No. : L-T670WDT-CW-U1

REV: A / 0

TEST ITEMS AND RESULTS

Test Item	Standard Test Method	Test Conditions	Note	Number of Damaged
Resistance to Soldering Heat (Reflow Soldering)	JEITA ED-4701 300 301	Tsld=180°C, 10sec. (Pre treatment 30°C, 70%, 168hrs)	2 times	0/20
Solderability (Reflow Soldering)	JEITA ED-4701 300 303	Tsld=240±5°C, 3sec. (Leader Solder)	1time over 95%	0/20
Thermal Shock	JEITA ED-4701 300 307	-40°C~100°C 5min. 5min.	100cycles	0/20
Temperature Cycle	JEITA ED-4701 100 105	-40°C~25°C~100°C~25°C 30min. 5min. 30min. 5min.	100cycles	0/20
Moisture Resistance Cycle	JEITA ED-4701 200 203	25°C~65°C~-10°C 90%RH 24hrs./1cycle	10 cycles	0/20
High Temperature Storage	JEITA ED-4701 200 201	Ta=100°C	1000 hrs	0/20
High Temperature High Humidity Storage	JEITA ED-4701 100 103	Ta=60°C, 90%RH	1000 hrs	0/20
Low Temperature Storage	JEITA ED-4701 200 202	Ta=-40°C	1000 hrs	0/20
Steady State Operating Life		Ta=25°C, If=20mA	1000 hrs	0/20
Steady State Operating Life of High Temperature		Ta=85°C, If=20mA	1000 hrs	0/20
Steady State Operating Life of High Humidity Heat		60°C, 90%RH, If=20mA	500 hrs	0/20
Steady State Operating Life of Low Temperature		Ta=-30°C, If=20mA	1000 hrs	0/20
Drop		H=75cm	3 cycles	0/20
Substrate Bending	JEITA ED-4702	3mm, 5 ± 1 sec.	1 time	0/20
Stick	JEITA ED-4702	5N, 10 ± 1 sec.	1 time	0/20



SURFACE MOUNT DEVICE LED

Part No. : L-T670WDT-CW-U1

REV: A / 0

(2) CRITERIA FOR JUDGING THE DAMAGE

Item	Symbol	Test Conditions	Criteria for Judgement	
			Min.	Max.
Forward Voltage	V_F	$I_F=20mA$	-	U.S.L. *)X1.1
Reverse Current	I_R	$V_R=5V$	-	U.S.L. *)X2.0
Luminous Intensity	I_V	$I_F=20mA$	L.S.L. **)X0.7	-

*) U.S.L. : Upper Standard Level

**) L.S.L. : Lower Standard Level

An instruction manual

1. The product affirms:

Before using this product, your company must conduct tests in advance to confirm whether it is suitable for use. The use of the product does not guarantee that it does not contradict any patent. The legal responsibility for the import and export of LED products should be borne by the customer. Please check the relevant regulations of each country or region in advance. The product may be modified due to performance improvement or change of specification parameters. We require formal product specification before mass production.

2. Material confirmation:

Whether the LED BIN grade of the feed is consistent, such as V_F , CIE BIN, brightness and so on, whether they belong to the same grade, and the same level should be used together. If not the same class of LED is applied to the same object, it should be evaluated first, (if different V_F or CIE BIN may be thrown together, the difference in brightness or color may occur).

3. Packaging and storage:

3.1, before opening packaging, avoid moisture into LED, SMD series LED is suggested to be stored in a drying cabinet with built-in desiccant. The storage environment is temperature 5-30 C, and the humidity is not more than 50%RH.



SURFACE MOUNT DEVICE LED

Part No. : L-T670WDT-CW-U1

REV: A / 0

3.2. Preventive measures after packing

LED is a surface mount. When the LED is welded, the internal separation of LED may occur. The luminescence efficiency is affected and the luminance decreases or the color variation.

The following are the matters to be paid attention to:

A, after the package is opened, welding should be completed as soon as possible (within 12 hours), and the ambient temperature is 20-30°C and the humidity should not exceed 65%RH.

B, the remaining material should be sealed or placed in 5 ~ 40 degrees C, humidity of not more than 30%RH environment.

Dehumidification measures and dehumidification conditions should be taken before C and surplus materials are used: bake for 12 hours at 60°C centigrade.

3.3, LED electrodes and stents are made up of silver plated copper alloy, and the silver layer is easily affected by corrosive gases. Please avoid contact corrosion environment to cause discoloration of LED, so as to avoid the deterioration of LED's weldability or influence the photoelectric properties. Avoid sudden changes in ambient temperature and humidity, especially in high humidity environment.

3.4. Materials stored in LED after two months should be returned to the factory for dehumidification and reuse.

4. Heat sink:

4.1, the LED application terminal products should consider the heat dissipation design. The LED power temperature rise coefficient is determined by the LED's layout density, thermal resistance and ambient temperature in the PCB. At design time, the heat generated by LED does not exceed its maximum limit (reference LED Tj junction temperature). Like other electronic components, it is necessary to avoid the design of the heating element.

4.2. When LED is working, consider that its working current should be determined by its maximum working junction temperature.



SURFACE MOUNT DEVICE LED

Part No. : L-T670WDT-CW-U1

REV: A / 0

5. Welding conditions:

5.1, whether the product is suitable for reflow soldering process, please refer to the corresponding product specification. Han Hua Guang does not guarantee the wetting way of welding.

5.2. Reflow soldering temperature and time refer to the corresponding product specification. LED is not suitable for two or more than two times of reflow soldering.

5.3, it is not recommended that LED be mounted on curved circuit boards. Avoid rapid cooling during welding. Avoid any mechanical or excessive vibration during the LED welding process. Do not bend the PCB after welding.

5.4, the completion of welding LED is not suitable for repair work. If it is unavoidable, double head iron should be adopted, but it should be confirmed in advance whether the repair will damage the characteristics of LED.

6. Electrostatic protection:

LED is an electrostatic sensitive electronic component. Various measures should be taken to avoid static electricity, such as wearing an electrostatic bracelet or anti-static gloves during use. All devices, equipment and instruments should be properly grounded. It is suggested to prevent the wave of the machine and equipment when the LED is attached. It is suggested that the LED product after the assembly be tested to check whether the LED is damaged by the static electricity. The white or blue light LED confirmation method is (Reference): the single chip of 1mA or 2.5V can not be lit or the brightness of the other LED is obviously darker than the other LED.

7. Cleaning and cleaning:

It is suggested that isopropanol be used to clean LED. If other solvents are to be cleaned, it is necessary to ensure that the solvent will not affect the epoxy, organosilicon, silica gel, and the silver plating layer of the scaffold. Ultrasonic cleaning is not recommended to avoid damage to LED. If it is unavoidable, pre test should be carried out before cleaning to confirm whether there is any adverse effect or potential hazard to LED.

8. Other matters of attention:

8.1, white LED is composed of Blu ray chips and special phosphors. Therefore, the luminous color of LED will change with the change of working current. Before using this factor, we should consider whether this factor can achieve the desired effect.

DRAWING NO. :DS-31P-18-0170

DATE : 2018-08-22 PAGE

9 of 10



SURFACE MOUNT DEVICE LED

Part No. : L-T670WDT-CW-U1

REV: A / 0

- 8.2, the application of products can not be considered radiation protection design.
- 8.3, gallium arsenide is used in some launch tubes. Such products are prohibited from breaking or burning in the process of discarding. Inhalation or drinking of gases or liquids produced during the disposal of such products is also dangerous.
- 8.4, LED exposure to sunlight for a long time or occasional exposure to ultraviolet rays may lead to colloidal or lens yellowing.
- 8.5, in order to ensure the photoelectric performance of LED, keep the surface of LED luminescent area clean and avoid fingerprints or other foreign bodies.
- 8.6, it is not recommended to cover other incompatible lipids on silica gel surface of LED.
- 8.7, in view of the form of suction nozzle, in addition to avoiding the mechanical external force acting on the silica gel surface, there is basically no restriction on the SMT mounting process.
- 8.8, please be careful to avoid interference with other components when LED is assembled.
- 8.9, when designing the circuit, we should prevent the instantaneous impact of the reverse voltage or overcurrent on the LED during the switch.
- 8.10, the LED bracket is a silver plated support, and silver is easily sulfurized with sulfur, resulting in the appearance and color variation of LED. The production and use environment should be avoided or away from sulfur.
- 8.11, during the use of tweezers and other sharp tools to avoid touching silicone gel parts.
- 8.12, the product conforms to the RoHs instruction, and the product's intention is mainly used in general electric equipment (such as office automation equipment, communication equipment, audio-visual equipment, household appliances, measuring tools, etc.), especially general lighting. Please contact our sales representative in advance, as soon as it is applied to products, such as aviation products, medical equipment, automatic control system, etc., which are directly affected by high reliability or failure due to failure.