



PARA LIGHT ELECTRONICS CO., LTD.
4F, No.1, Lane 93, Chien Yi Road, Chung Ho City, Taipei, Taiwan
Tel: 886-2-2225-3733 Fax: 886-2-2225-4800
E-mail: para@para.com.tw <http://www.para.com.tw>

DATA SHEET

PART NO.: L-S020WDT-U1

REV: A/1

CUSTOMER'S APPROVAL : _____

DCC :

● **Features**

- 020 package.
- Side View White LED.
- wide viewing angle.
- Compatible with infrared and vapor phase reflow solder process.
- Package:4000pcs/reel
- Pb-free.

● **Applications**

- Backlighting in dashboard and switch.
- Flat backlight for LCD
- Switch and symbol.
- General use.

● **Package Outline Dimensions**

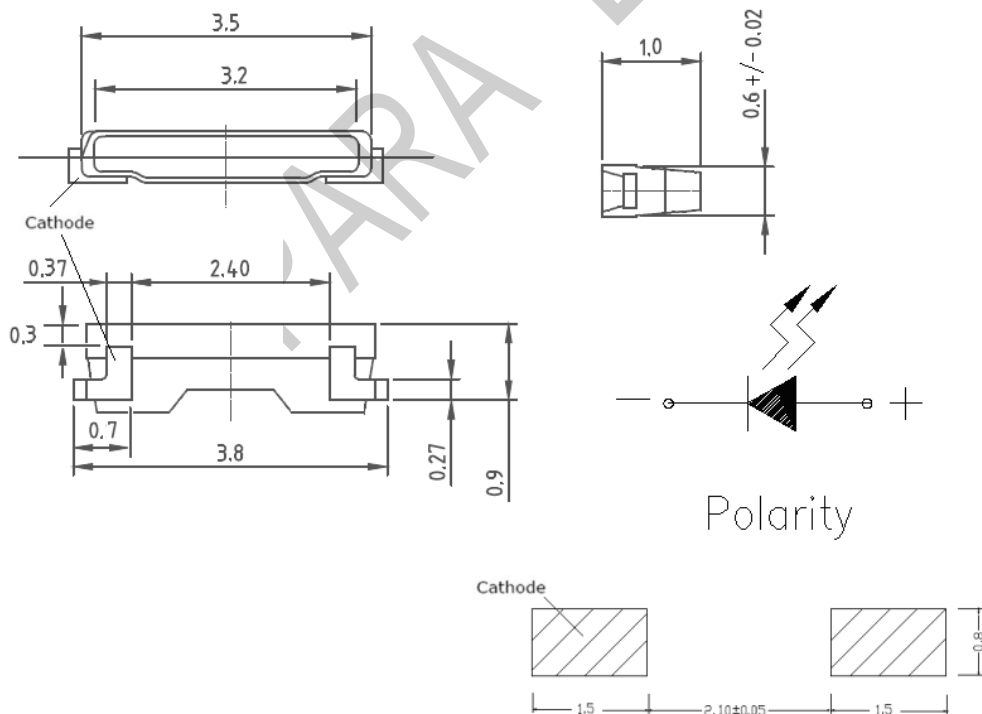

Note: 1.The thickness tolerance is +/-0.02mm

2.All the other dimensions is ±0.1mm unless otherwise noted, Unit = mm

● CHIP MATERIALS

- * Dice Material : InGaN
- * Light Color : Cool White
- * Lens Color : Yellow Diffused.

● Absolute Maximum Ratings(Ta=25°C)

Parameter	Symbol	Typical	Unit
Power dissipation	Pd	100	mW
DC forward current	If	30	mA
Reverse voltage	Vr	5	V
Operating temperature range	Top	-35 ~+85	°C
Storage temperature range	Tstg	-40~+100	°C
Peak pulsing current	Ifp	60	mA
Electrostatic Discharge	ESD	2000(HBM)	V

IFP Conditions: Pulse Width ≤ 10msec. and Duty cycle ≤ 1/10.

Electro-Optical Characteristics (Ta=25°C)

Parameter	Symbol	Min.	Typ.	Max.	Unit	Test Condition
Luminous Intensity	IV	1800		3700	mcd	IF=20mA
Viewing Angle	2θ1/2		110		Deg	Note 2
Forward Voltage	VF	2.80		3.40	V	IF = 20mA

* The luminous intensity tolerance is ±10%

** The forward voltage tolerance is ±0.05V

*** The CIE Chromaticity tolerance is ±0.005



SURFACE MOUNT DEVICE LED

Part No. : L-S020WDT-U1

REV: A/1

● Bin Code List

Bin	Min	Max	Unit	Condition
D18	1800	1900	mcd	$I_f=20\text{mA}$
D19	1900	2000		
D20	2000	2100		
D21	2100	2200		
D22	2200	2300		
D23	2300	2400		
D24	2400	2500		
D25	2500	2600		
D26	2600	2700		
D27	2700	2800		
D28	2800	2900		
D29	2900	3000		
D30	3000	3100		
D31	3100	3200		
D32	3200	3300		
D33	3300	3400		
D34	3400	3500		
D35	3500	3600		
D36	3600	3700		

Bin	Bin	Min	Max	Unit	Condition
M1	6	2.8	2.9	V	$I_f=20\text{mA}$
	7	2.9	3.0		
	8	3.0	3.1		
	9	3.1	3.2		
	A	3.2	3.3		
	B	3.3	3.4		

● C.I.E Chromaticity Diagram

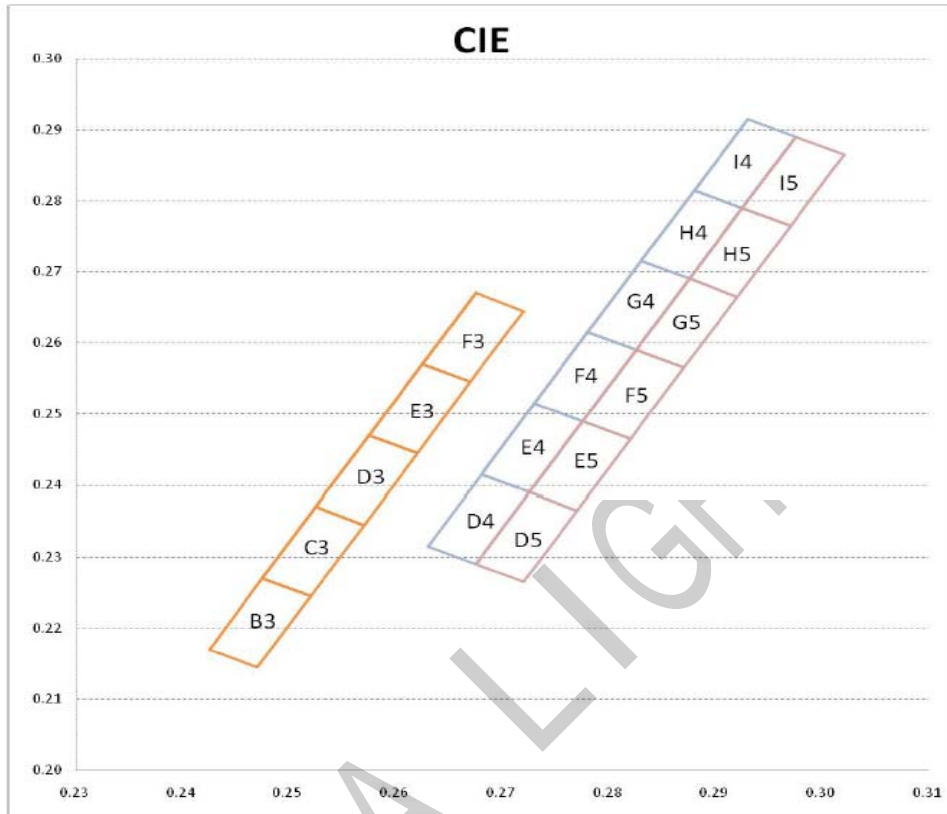

Code	CIE X	CIE Y	Code	CIE X	CIE Y	Code	CIE X	CIE Y
B3	0.2475	0.2270	D4	0.2680	0.2415	D5	0.2725	0.2390
	0.2425	0.2170		0.2630	0.2315		0.2675	0.2290
	0.2470	0.2145		0.2675	0.2290		0.2720	0.2265
	0.2520	0.2245		0.2725	0.2390		0.2770	0.2365
	0.2475	0.2270		0.2680	0.2415		0.2725	0.2390
C3	0.2525	0.2370	E4	0.2730	0.2515	E5	0.2775	0.2490
	0.2475	0.2270		0.2680	0.2415		0.2725	0.2390
	0.2520	0.2245		0.2725	0.2390		0.2770	0.2365
	0.2570	0.2345		0.2775	0.2490		0.2820	0.2465
D3	0.2525	0.2370	F4	0.2730	0.2515	F5	0.2775	0.2490
	0.2575	0.2470		0.2780	0.2615		0.2825	0.2590
	0.2525	0.2370		0.2730	0.2515		0.2775	0.2490
	0.2570	0.2345		0.2775	0.2490		0.2820	0.2465
E3	0.2620	0.2445	G4	0.2825	0.2590	G5	0.2870	0.2565
	0.2625	0.2570		0.2830	0.2715		0.2875	0.2690
	0.2575	0.2470		0.2780	0.2615		0.2920	0.2665
	0.2670	0.2545		0.2875	0.2690		0.2920	0.2665
F3	0.2625	0.2570	H4	0.2830	0.2715	H5	0.2875	0.2690
	0.2675	0.2670		0.2880	0.2815		0.2925	0.2790
	0.2625	0.2570		0.2830	0.2715		0.2875	0.2690
	0.2670	0.2545		0.2875	0.2690		0.2920	0.2665
	0.2720	0.2645		0.2925	0.2790		0.2970	0.2765
I4	0.2675	0.2670	I4	0.2880	0.2815	I5	0.2925	0.2790
	0.2625	0.2570		0.2930	0.2915		0.2975	0.2890
	0.2670	0.2545		0.2880	0.2815		0.2925	0.2790
	0.2720	0.2645		0.2925	0.2790		0.2970	0.2765
	0.2675	0.2670		0.2975	0.2890		0.3020	0.2865
			0.2930	0.2915	0.2975	0.2890		

● Typical Electro-Optical Characteristics Curves

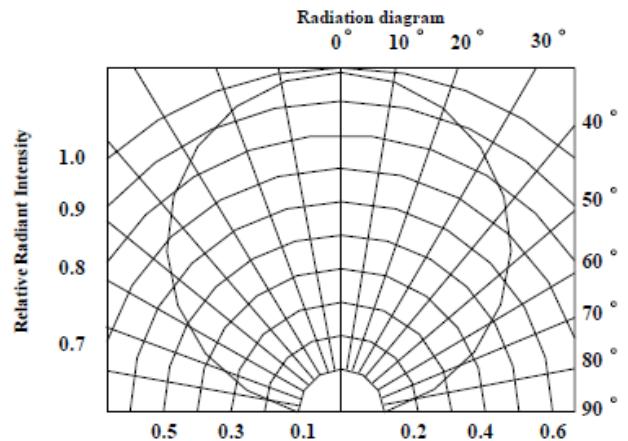
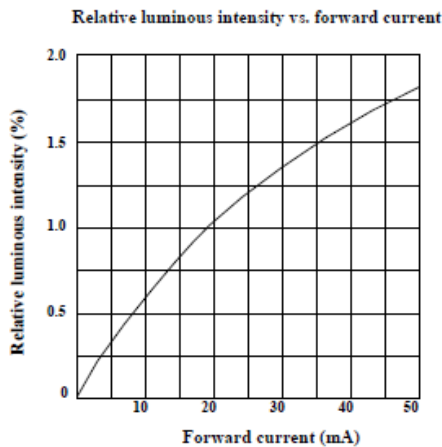
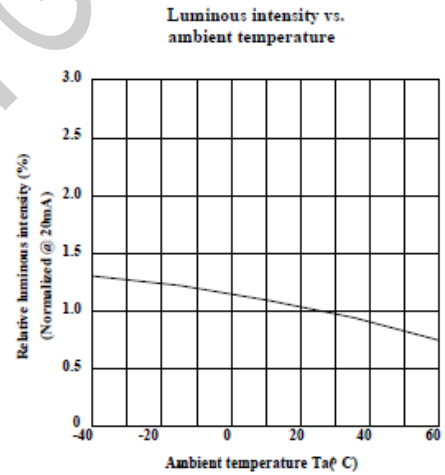
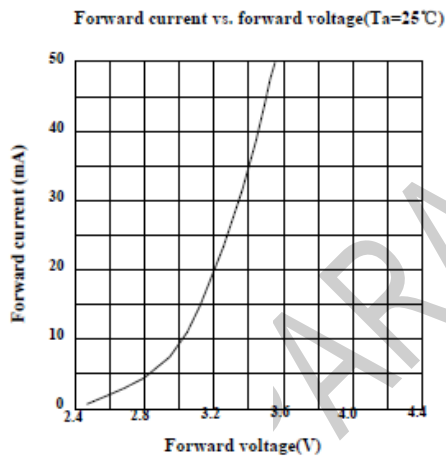
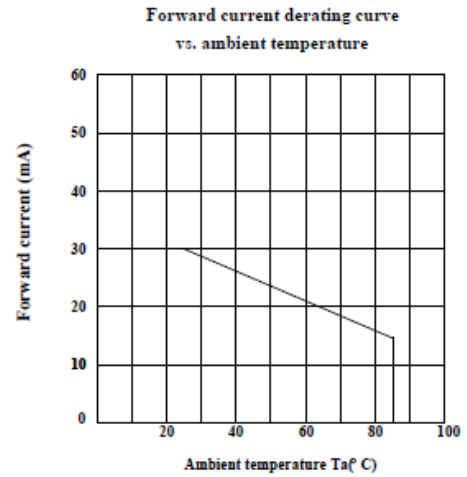
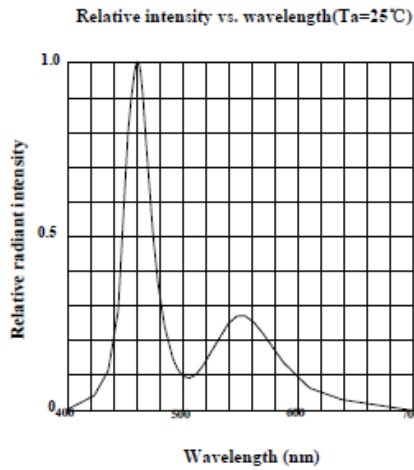

● Label Explanation

光鼎電子股份有限公司
 PARALIGHT ELECTRONICS CO., LTD
 CUS.PART NO: A
 CUSTOMER: B
 PART NO : LS020WDT-U1-DS
 IV : XX
 LOT NO: C VF: XX
 CIE: XX
 QUANTITY: XXXXPCS
 QC:
 DATE CODE: 20080901

● Package Dimensions Of Tape And Reel

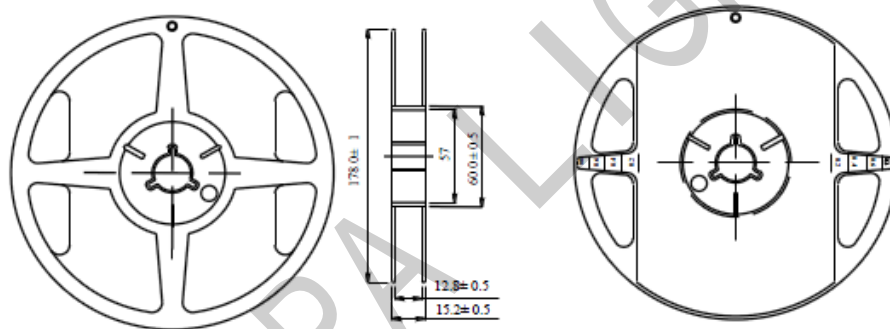

Notes:

1. All dimensions are in mm, tolerance is $\pm 2.0\text{mm}$ unless otherwise noted.
2. Specifications are subject to change without notice.

● Dimensions of Tape (Unit: mm)

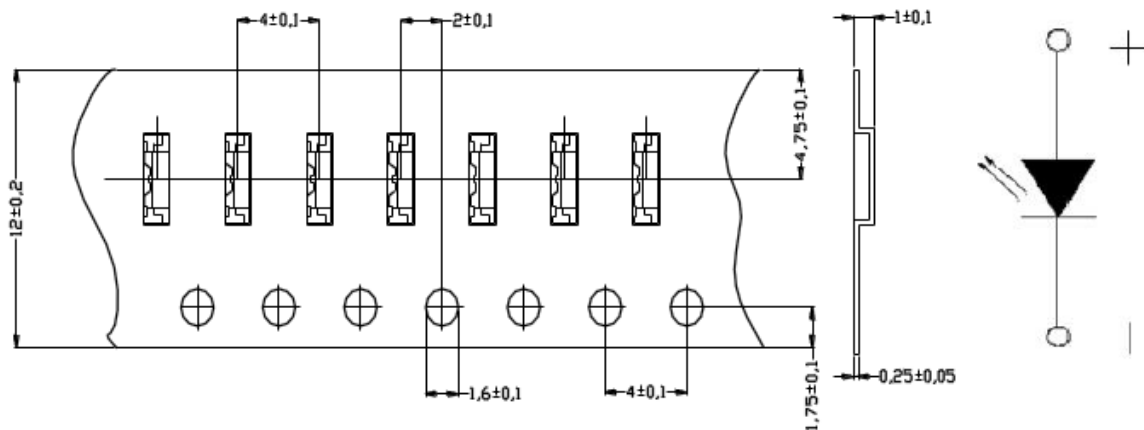

● **Moisture Resistant Packaging**

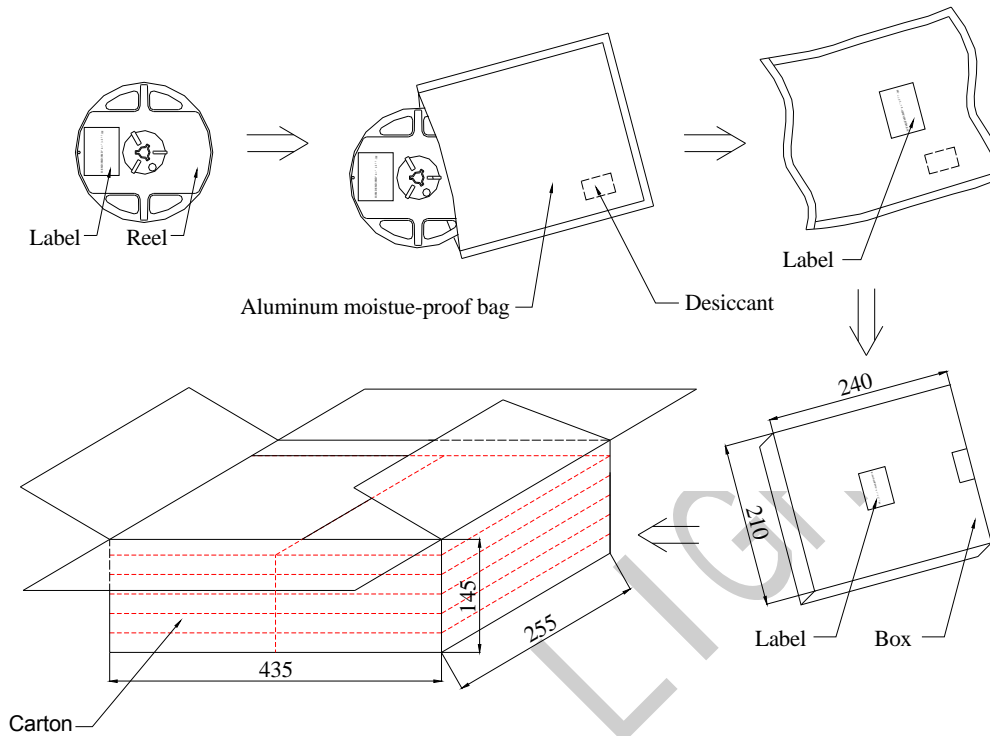

Notes:

The tolerances unless noted is $\pm 0.1\text{mm}$, Angle $\pm 0.5^\circ$, Unit: mm

● Reliability Test Items And Conditions

The reliability of products shall be satisfied with items listed below.

Confidence level : 85 % LTPD : 15 %

No.	Items	Test Condition	Test Hours/Cycles	Sample Size
1	Reflow Soldering	Temp. : 260°C±5°C Min. 5sec.	6 Min.	22 PCS.
2	Temperature Cycle	H : +100°C 15min ∫ 5 min L : -40°C 15min	300 Cycles	22 PCS.
3	Thermal Shock	H : +100°C 5min ∫ 10 sec L : -10°C 5min	300 Cycles	22 PCS.
4	High Temperature Storage	Temp. : 100°C	1000 Hrs.	22 PCS.
5	Low Temperature Storage	Temp. : -40°C	1000 Hrs.	22 PCS.
6	DC Operating Life	I _F = 20 mA	1000 Hrs.	22 PCS.
7	High Temperature / High Humidity Storage	70°C / 90% RH	1000 Hrs.	22 PCS.
8	High Temperature / High Humidity Operation	70°C / 90% RH I _F =20mA	1000 Hrs.	22 PCS.
9	High Temperature Operation	Temp. : 70°C I _F =20mA	1000 Hrs.	22 PCS.

● Soldering Condition:

1. Pb-free solder temperature profile

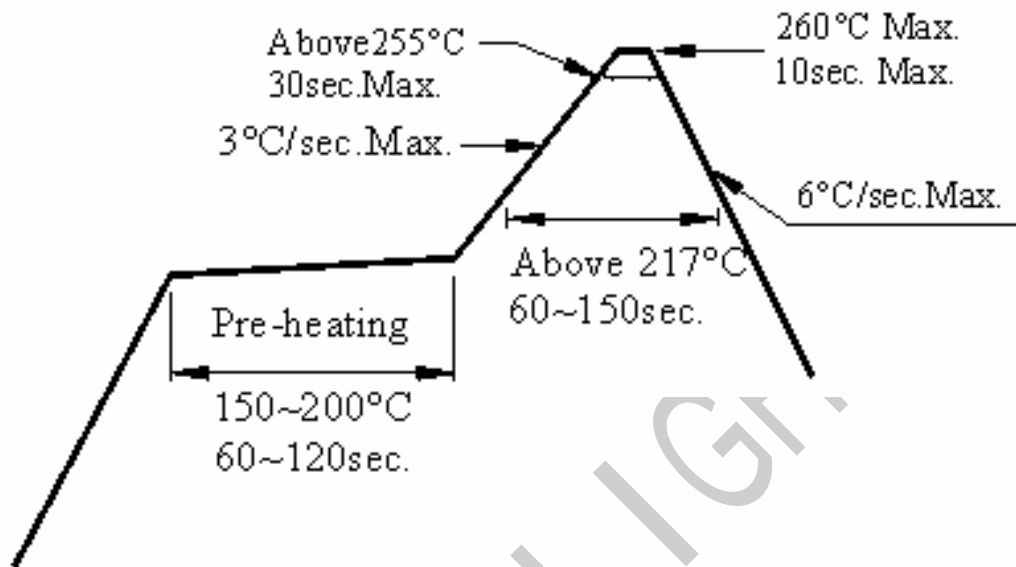

2. Reflow soldering should not be done more than two times.
3. When soldering, do not put stress on the LEDs during heating.
4. After soldering, do not warp the circuit board.

Storage

1. Do not open moisture proof bag before the products are ready to use.
2. Before opening the package: The LEDs should be kept at 30°C or less and 90%RH or less.
3. After opening the package: The LED's floor life is 1 year under 30°C or less and 60% RH or less. If unused LEDs remain, it should be stored in moisture proof packages.
4. If the moisture absorbent material (silica gel) has faded away or the LEDs have exceeded the storage time, baking treatment should be performed using the following conditions.
Baking treatment : 60±5°C for 24 hours.